



High Performance Single Chip Low Power 10/100 Ethernet Physical Layer Transceiver (PHY)

PRODUCT FEATURES

[Datasheet](#)

- Single Chip Ethernet Phy
- Fully compliant with IEEE 802.3/802.3u standards
- 10BASE-T and 100BASE-TX support
- Supports Auto-negotiation and Parallel Detection
- Automatic Polarity Correction
- Integrated DSP with Adaptive Equalizer
- Baseline Wander (BLW) Correction
- Media Independent Interface (MII)
- 802.3u compliant register functions
- Vendor Specific register functions
- Comprehensive power management features
- General power-down mode
- Energy Detect power-down mode
- Low profile 64-pin TQFP package; lead-free RoHS compliant package also available
- Single +3.3V supply with 5V tolerant I/O
- 0.18 micron technology
- Low power consumption
- Operating Temperature 0° C to 70° C
- Internal +1.8V Regulator

Applications

- LAN on Motherboard
- 10/100 PCMCIA/CardBus Applications
- Embedded Telecom Applications
- Video Record/Playback Systems
- Cable Modems And Set-Top Boxes
- Digital Televisions
- Wireless Access Points

ORDER NUMBERS:

LAN83C185-JD FOR 64-PIN TQFP PACKAGE

LAN83C185-JT FOR 64-PIN TQFP LEAD-FREE ROHS COMPLIANT PACKAGE



80 ARKAY DRIVE, HAUPPAUGE, NY 11788 (631) 435-6000, FAX (631) 273-3123

Copyright © 2008 SMSC or its subsidiaries. All rights reserved.

Circuit diagrams and other information relating to SMSC products are included as a means of illustrating typical applications. Consequently, complete information sufficient for construction purposes is not necessarily given. Although the information has been checked and is believed to be accurate, no responsibility is assumed for inaccuracies. SMSC reserves the right to make changes to specifications and product descriptions at any time without notice. Contact your local SMSC sales office to obtain the latest specifications before placing your product order. The provision of this information does not convey to the purchaser of the described semiconductor devices any licenses under any patent rights or other intellectual property rights of SMSC or others. All sales are expressly conditional on your agreement to the terms and conditions of the most recently dated version of SMSC's standard Terms of Sale Agreement dated before the date of your order (the "Terms of Sale Agreement"). The product may contain design defects or errors known as anomalies which may cause the product's functions to deviate from published specifications. Anomaly sheets are available upon request. SMSC products are not designed, intended, authorized or warranted for use in any life support or other application where product failure could cause or contribute to personal injury or severe property damage. Any and all such uses without prior written approval of an Officer of SMSC and further testing and/or modification will be fully at the risk of the customer. Copies of this document or other SMSC literature, as well as the Terms of Sale Agreement, may be obtained by visiting SMSC's website at <http://www.smisc.com>. SMSC is a registered trademark of Standard Microsystems Corporation ("SMSC"). Product names and company names are the trademarks of their respective holders.

SMSC DISCLAIMS AND EXCLUDES ANY AND ALL WARRANTIES, INCLUDING WITHOUT LIMITATION ANY AND ALL IMPLIED WARRANTIES OF MERCHANTABILITY, FITNESS FOR A PARTICULAR PURPOSE, TITLE, AND AGAINST INFRINGEMENT AND THE LIKE, AND ANY AND ALL WARRANTIES ARISING FROM ANY COURSE OF DEALING OR USAGE OF TRADE. IN NO EVENT SHALL SMSC BE LIABLE FOR ANY DIRECT, INCIDENTAL, INDIRECT, SPECIAL, PUNITIVE, OR CONSEQUENTIAL DAMAGES; OR FOR LOST DATA, PROFITS, SAVINGS OR REVENUES OF ANY KIND; REGARDLESS OF THE FORM OF ACTION, WHETHER BASED ON CONTRACT; TORT; NEGLIGENCE OF SMSC OR OTHERS; STRICT LIABILITY; BREACH OF WARRANTY; OR OTHERWISE; WHETHER OR NOT ANY REMEDY OF BUYER IS HELD TO HAVE FAILED OF ITS ESSENTIAL PURPOSE, AND WHETHER OR NOT SMSC HAS BEEN ADVISED OF THE POSSIBILITY OF SUCH DAMAGES.

Table of Contents

Chapter 1	General Description	8
1.1	Architectural Overview	8
Chapter 2	Pin Configuration	9
Chapter 3	Pin Description	11
3.1	I/O Signals	11
Chapter 4	Architecture Details	16
4.1	Top Level Functional Architecture	16
4.2	100Base-TX Transmit	16
4.2.1	100M Transmit Data across the MII	16
4.2.2	4B/5B Encoding	16
4.2.3	Scrambling	18
4.2.4	NRZI and MLT3 Encoding	18
4.2.5	100M Transmit Driver	18
4.2.6	100M Phase Lock Loop (PLL)	18
4.3	100Base-TX Receive	19
4.3.1	100M Receive Input	19
4.3.2	Equalizer, Baseline Wander Correction and Clock and Data Recovery	19
4.3.3	NRZI and MLT-3 Decoding	19
4.3.4	Descrambling	20
4.3.5	Alignment	20
4.3.6	5B/4B Decoding	20
4.3.7	Receive Data Valid Signal	20
4.3.8	Receiver Errors	21
4.3.9	100M Receive Data across the MII	21
4.4	10Base-T Transmit	21
4.4.1	10M Transmit Data across the MII	21
4.4.2	Manchester Encoding	21
4.4.3	10M Transmit Drivers	21
4.5	10Base-T Receive	22
4.5.1	10M Receive Input and Squelch	22
4.5.2	Manchester Decoding	22
4.5.3	10M Receive Data across the MII	22
4.5.4	Jabber detection	22
4.6	MAC Interface	22
4.6.1	MII	23
4.7	Auto-negotiation	23
4.7.1	Parallel Detection	24
4.7.2	Re-starting Auto-negotiation	25
4.7.3	Disabling Auto-negotiation	25
4.7.4	Half vs. Full Duplex	25
4.8	PHY Management Control	25
4.8.1	Serial Management Interface (SMI)	25
Chapter 5	Registers	27
5.1	SMI Register Mapping	33
5.2	SMI Register Format	33
5.3	Management Interrupt	42
5.4	Miscellaneous Functions	42

5.4.1	Carrier Sense	42
5.4.2	Collision Detect	43
5.4.3	Isolate Mode	43
5.4.4	Link integrity Test	43
5.4.5	Power-Down modes	43
5.4.6	Reset	44
5.4.7	LED Description	44
5.4.8	Loopback Operation	45
5.4.9	Configuration Signals	45
5.5	Analog	46
5.5.1	ADC	46
5.5.2	100M PLL	47
5.5.3	MT_100	47
5.5.4	10M Squelch	47
5.5.5	10BT Filter	47
5.5.6	10M PLL - Data Recovery Clock	47
5.5.7	PLL 10M - Transmit Clock	48
5.5.8	XMT_10	48
5.5.9	Central Bias	48
5.6	DSP Block	49
5.6.1	General Description	49
5.6.2	ADC Gray code converting	49
<hr/>		
Chapter 6 Electrical Characteristics		50
6.1	Serial Management Interface (SMI) Timing	50
6.2	100Base-TX Timings	51
6.2.1	100M MII Receive Timing	51
6.2.2	100M MII Transmit Timing	51
6.3	10Base-T Timings	52
6.3.1	10M MII Receive Timing	52
6.3.2	10M MII Transmit Timing	52
6.4	Reset Timing	53
6.5	DC Characteristics	54
6.5.1	Operating Conditions	54
6.5.2	Power Consumption	54
6.5.3	DC Characteristics - Input and Output Buffers	56
<hr/>		
Chapter 7 Package Outline		60



Datasheet

List of Figures

Figure 1.1	LAN83C185 Architectural Overview	8
Figure 2.1	Package Pinout	9
Figure 4.1	100Base-TX Data Path	16
Figure 4.2	Receive Data Path	19
Figure 4.3	Relationship Between Received Data and Some MII Signals	20
Figure 4.4	MDIO Timing and Frame Structure - READ Cycle	26
Figure 4.5	MDIO Timing and Frame Structure - WRITE Cycle	26
Figure 5.1	PHY Address Strapping on LEDES	45
Figure 7.1	64 Pin TQFP Package Outline, 10X10X1.4 Body, 2 MM Footprint	60

List of Tables

Table 2.1	LAN83C185 64-PIN TQFP Pinout	10
Table 3.1	MII Signals	11
Table 3.2	LED Signals	12
Table 3.3	Management Signals	12
Table 3.4	Configuration Inputs	13
Table 3.5	General Signals	13
Table 3.6	10/100 Line Interface	14
Table 3.7	Analog References	14
Table 3.8	Analog Test Bus	14
Table 3.9	Power Signals	14
Table 4.1	4B/5B Code Table	17
Table 5.1	Control Register: Register 0 (Basic)	27
Table 5.2	Status Register: Register 1 (Basic)	27
Table 5.3	PHY ID 1 Register: Register 2 (Extended)	27
Table 5.4	PHY ID 2 Register: Register 3 (Extended)	27
Table 5.5	Auto-Negotiation Advertisement: Register 4 (Extended)	27
Table 5.6	Auto-Negotiation Link Partner Base Page Ability Register: Register 5 (Extended)	28
Table 5.7	Auto-Negotiation Expansion Register: Register 6 (Extended)	28
Table 5.8	Auto-Negotiation Link Partner Next Page Transmit Register: Register 7 (Extended)	28
Table 5.9	Register 8 (Extended)	28
Table 5.10	Register 9 (Extended)	28
Table 5.11	Register 10 (Extended)	29
Table 5.12	Register 11 (Extended)	29
Table 5.13	Register 12 (Extended)	29
Table 5.14	Register 13 (Extended)	29
Table 5.15	Register 14 (Extended)	29
Table 5.16	Register 15 (Extended)	29
Table 5.17	Silicon Revision Register 16: Vendor-Specific	30
Table 5.18	Mode Control/ Status Register 17: Vendor-Specific	30
Table 5.19	Special Modes Register 18: Vendor-Specific	30
Table 5.20	Reserved Register 19: Vendor-Specific	30
Table 5.21	TSTCNTL Register 20: Vendor-Specific	30
Table 5.22	TSTREAD2 Register 21: Vendor-Specific	31
Table 5.23	TSTREAD1 Register 22: Vendor-Specific	31
Table 5.24	TSTWRITE Register 23: Vendor-Specific	31
Table 5.25	Register 24: Vendor-Specific	31
Table 5.26	Register 25: Vendor-Specific	31
Table 5.27	Register 26: Vendor-Specific	31
Table 5.28	Special Control/Status Indications Register 27: Vendor-Specific	32
Table 5.29	Special Internal Testability Control Register 28: Vendor-Specific	32
Table 5.30	Interrupt Source Flags Register 29: Vendor-Specific	32
Table 5.31	Interrupt Mask Register 30: Vendor-Specific	32
Table 5.32	PHY Special Control/Status Register 31: Vendor-Specific	32
Table 5.33	SMI Register Mapping	33
Table 5.34	Register 0 - Basic Control	34
Table 5.35	Register 1 - Basic Status	34
Table 5.36	Register 2 - PHY Identifier 1	35
Table 5.37	Register 3 - PHY Identifier 2	35
Table 5.38	Register 4 - Auto Negotiation Advertisement	35
Table 5.39	Register 5 - Auto Negotiation Link Partner Ability	36
Table 5.40	Register 6 - Auto Negotiation Expansion	37
Table 5.41	Register 16 - Silicon Revision	37

**Datasheet**

Table 5.42 Register 17 - Mode Control/Status	37
Table 5.43 Register 18 - Special Modes	38
Table 5.44 Register 20 - TSTCNTL	39
Table 5.45 Register 21 - TSTREAD1	39
Table 5.46 Register 22 - TSTREAD2	39
Table 5.47 Register 23 - TSTWRITE	40
Table 5.48 Register 27 - Special Control/Status Indications	40
Table 5.49 Register 28 - Special Internal Testability Controls	40
Table 5.50 Register 29 - Interrupt Source Flags	40
Table 5.51 Register 30 - Interrupt Mask	41
Table 5.52 Register 31 - PHY Special Control/Status	41
Table 5.53 MODE[2:0] Bus	46
Table 6.1 Power Consumption Device Only	54
Table 6.2 Power Consumption Device and System Components	55
Table 6.3 MII Bus Interface Signals	56
Table 6.4 LAN Interface Signals	57
Table 6.5 LED Signals	57
Table 6.6 Configuration Inputs	57
Table 6.7 General Signals	58
Table 6.8 Analog References	58
Table 6.9 Internal Pull-Up / Pull-/Down Configurations	58
Table 6.10 100Base-TX Transceiver Characteristics	59
Table 6.11 10BASE-T Transceiver Characteristics	59
Table 7.1 64 Pin TQFP Package Parameters	60

Chapter 1 General Description

The SMSC LAN83C185 is a low-power, highly integrated analog interface IC for high-performance embedded Ethernet applications. The LAN83C185 requires only a single +3.3V supply.

The LAN83C185 consists of an encoder/decoder, scrambler/descrambler, transmitter with wave-shaping and output driver, twisted-pair receiver with on-chip adaptive equalizer and baseline wander (BLW) correction, clock and data recovery, and Media Independent Interface (MII).

The LAN83C185 is fully compliant with IEEE 802.3/ 802.3u standards and supports both 802.3u-compliant and vendor-specific register functions. It contains a full-duplex 10-BASE-T/100BASE-TX transceiver and supports 10-Mbps (10BASE-T) operation on Category 3 and Category 5 unshielded twisted-pair cable, and 100-Mbps (100BASE-TX) operation on Category 5 unshielded twisted-pair cable.

1.1 Architectural Overview

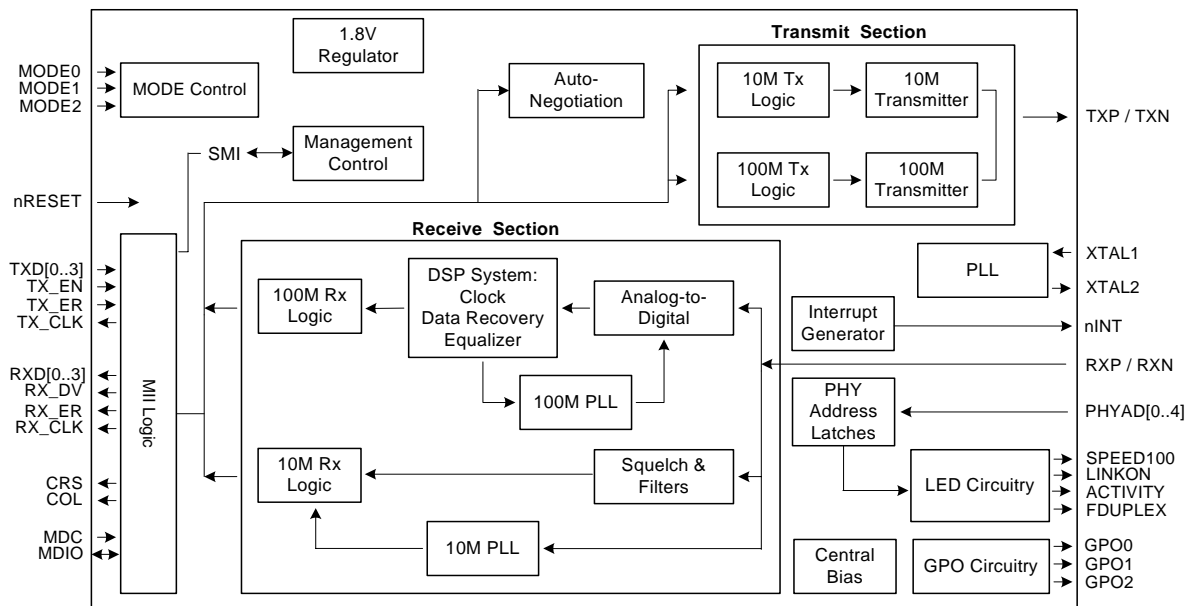

Figure 1.1 LAN83C185 Architectural Overview

Chapter 2 Pin Configuration

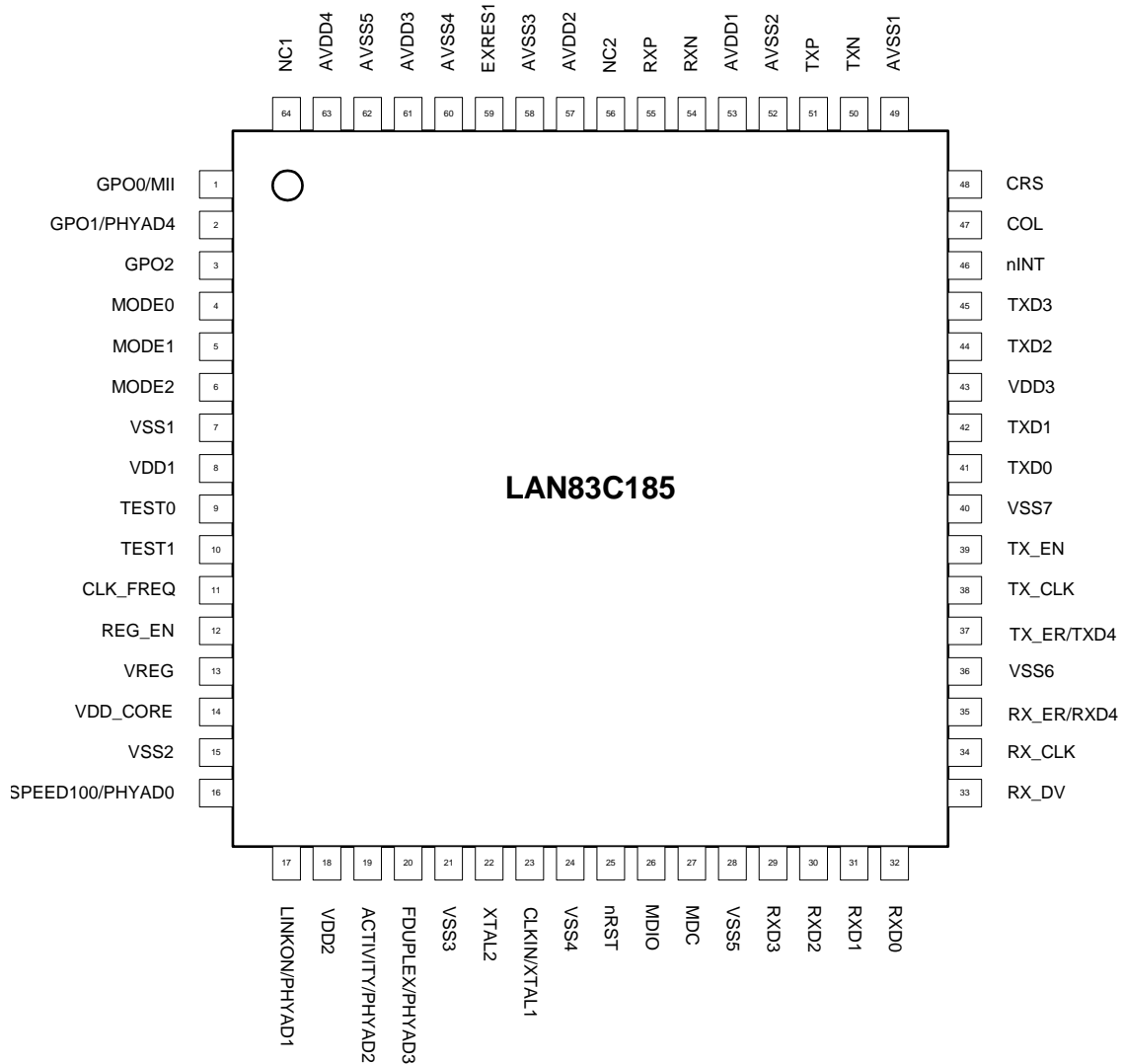

Figure 2.1 Package Pinout

Table 2.1 LAN83C185 64-PIN TQFP Pinout

PIN NO.	PIN NAME	PIN NO.	PIN NAME
1	GPO0/MII	33	RX_DV
2	GPO1/PHYAD4	34	RX_CLK
3	GPO2	35	RX_ER/RXD4
4	MODE0	36	VSS6
5	MODE1	37	TX_ER/TXD4
6	MODE2	38	TX_CLK
7	VSS1	39	TX_EN
8	VDD1	40	VSS7
9	TEST0	41	TXD0
10	TEST1	42	TXD1
11	CLK_FREQ	43	VDD3
12	REG_EN	44	TXD2
13	VREG	45	TXD3
14	VDD_CORE	46	nINT
15	VSS2	47	COL
16	SPEED100/PHYAD0	48	CRS
17	LINKON/PHYAD1	49	AVSS1
18	VDD2	50	TXN
19	ACTIVITY/PHYAD2	51	TXP
20	FDUPLEX/PHYAD3	52	AVSS2
21	VSS3	53	AVDD1
22	XTAL2	54	RXN
23	CLKIN/XTAL1	55	RXP
24	VSS4	56	NC2
25	nRST	57	AVDD2
26	MDIO	58	AVSS3
27	MDC	59	EXRES1
28	VSS5	60	AVSS4
29	RXD3	61	AVDD3
30	RXD2	62	AVSS5
31	RXD1	63	AVDD4
32	RXD0	64	NC1

Chapter 3 Pin Description

This chapter describes in detail the functionality of each of the five main architectural blocks.

The term “block” defines a stand-alone entity on the floor plan of the chip.

3.1 I/O Signals

I – Input. Digital TTL levels.

O – Output. Digital TTL levels.

AI – Input. Analog levels.

AO – Output. Analog levels.

AI/O – Input or Output. Analog levels.

Note: Reset as used in the signal descriptions is defined as nRST being active low.

Configuration inputs are listed in parenthesis.

Table 3.1 MII Signals

PIN NO.	SIGNAL NAME	TYPE	DESCRIPTION
41	TXD0	I	Transmit Data 0: Bit 0 of the 4 data bits that are accepted by the PHY for transmission.
42	TXD1	I	Transmit Data 1: Bit 1 of the 4 data bits that are accepted by the PHY for transmission.
39	TX_EN	I	Transmit Enable: Indicates that valid data is presented on the TXD[3:0] signals, for transmission.
35	RX_ER (RXD4)	O O	Receive Error: Asserted to indicate that an error was detected somewhere in the frame presently being transferred from the PHY. In Symbol Interface (5B Decoding) mode, this signal is the MII Receive Data 4: the MSB of the received 5-bit symbol code-group.
47	COL	O	MII Collision Detect: Asserted to indicate detection of collision condition.
32	RXD0	O	Receive Data 0: Bit 0 of the 4 data bits that are sent by the PHY in the receive path.
31	RXD1	O	Receive Data 1: Bit 1 of the 4 data bits that are sent by the PHY in the receive path.
44	TXD2	I	Transmit Data 2: Bit 2 of the 4 data bits that are accepted by the PHY for transmission.
45	TXD3	I	Transmit Data 3: Bit 3 of the 4 data bits that are accepted by the PHY for transmission.

Table 3.1 MII Signals (continued)

PIN NO.	SIGNAL NAME	TYPE	DESCRIPTION
37	TX_ER (TXD4)	I	<p>MI1 Transmit Error: When driven high, the 4B/5B encode process substitutes the Transmit Error code-group (/H/) for the encoded data word. This input is ignored in 10BaseT operation.</p> <p>In Symbol Interface (5B Decoding) mode, this signal becomes the MI1 Transmit Data 4: the MSB of the 5-bit symbol code-group.</p>
48	CRS	O	Carrier Sense: Indicate detection of carrier.
33	RX_DV	O	Receive Data Valid: Indicates that recovered and decoded data nibbles are being presented on RXD[3:0].
30	RXD2	O	Receive Data 2: Bit 2 of the 4 data bits that sent by the PHY in the receive path.
29	RXD3	O	Receive Data 3: Bit 3 of the 4 data bits that sent by the PHY in the receive path.
38	TX_CLK	O	Transmit Clock: 25MHz in 100Base-TX mode. 2.5MHz in 10Base-T mode.
34	RX_CLK	O	Receive Clock: 25MHz in 100Base-TX mode. 2.5MHz in 10Base-T mode.

Table 3.2 LED Signals

PIN NO.	SIGNAL NAME	TYPE	DESCRIPTION
16	SPEED100	O	LED1 – SPEED100 indication. Active indicates that the selected speed is 100Mbps. Inactive indicates that the selected speed is 10Mbps.
17	LINKON	O	LED2 – LINK ON indication. Active indicates that the Link (100Base-TX or 10Base-T) is on.
19	ACTIVITY	O	LED3 – ACTIVITY indication. Active indicates that there is Carrier sense (CRS) from the active PMD.
20	FDUPLEX	O	LED4 – DUPLEX indication. Active indicates that the PHY is in full-duplex mode.

Table 3.3 Management Signals

PIN NO.	SIGNAL NAME	TYPE	DESCRIPTION
26	MDIO	IO	Management Data Input/OUTPUT: Serial management data input/output.
27	MDC	I	Management Clock: Serial management clock.

Table 3.4 Configuration Inputs

PIN NO.	SIGNAL NAME	TYPE	DESCRIPTION
2	PHYAD4	I	PHY Address Bit 4: set the default address of the PHY.
20	PHYAD3	I	PHY Address Bit 3: set the default address of the PHY.
19	PHYAD2	I	PHY Address Bit 2: set the default address of the PHY.
17	PHYAD1	I	PHY Address Bit 1: set the default address of the PHY.
16	PHYAD0	I	PHY Address Bit 0: set the default address of the PHY.
6	MODE2	I	PHY Operating Mode Bit 2: set the default MODE of the PHY. See Section 5.4.9.2, "Mode Bus – MODE[2:0]," on page 46 for the MODE options.
5	MODE1	I	PHY Operating Mode Bit 1: set the default MODE of the PHY. See Section 5.4.9.2, "Mode Bus – MODE[2:0]," on page 46 for the MODE options.
4	MODE0	I	PHY Operating Mode Bit 0: set the default MODE of the PHY. See Section 5.4.9.2, "Mode Bus – MODE[2:0]," on page 46 for the MODE options.
10	TEST1	I	Test Mode Select 1: Must be left floating.
9	TEST0	I	Test Mode Select 0: Must be left floating.
12	REG_EN	I	Internal +1.8V Regulator Enable: +3.3V – Enables internal regulator. 0V – Disables internal regulator.

Table 3.5 General Signals

PIN NO.	SIGNAL NAME	TYPE	DESCRIPTION
46	nINT	OD	LAN Interrupt – Active Low output.
25	nRST	I	External Reset – input of the system reset. This signal is active LOW.
23	CLKIN/XTAL1	I	Clock Input – 25 MHz external clock or crystal input.
22	XTAL2	O	Clock Output – 25 MHz crystal output.
11	CLK_FREQ	I	Clock Frequency – define the frequency of the input clock CLKIN 0 – Clock frequency is 25 MHz. 1 – Reserved. This input needs to be held low continuously, during and after reset. This pin should be pulled-down to VSS via a pull-down resistor.
64	NC1		No Connect
3	GPO2	O	General Purpose Output 2 – General Purpose Output signal Driven by bits in registers 27 and 31.
2	GPO1	O	General Purpose Output 1 – General Purpose Output signal Driven by bits in registers 27 and 31. (Muxed with PHYAD4 signal)

Table 3.5 General Signals (continued)

PIN NO.	SIGNAL NAME	TYPE	DESCRIPTION
1	GPO0	O	General Purpose Output 0 – General Purpose Output signal. Driven by bits in registers 27 and 31. (Muxed with MII Select) This pin should be pulled-down or left floating – Do Not Pull Up.

Table 3.6 10/100 Line Interface

PIN NO.	SIGNAL NAME	TYPE	DESCRIPTION
51	TXP	AO	Transmit Data: 100Base-TX or 10Base-T differential transmit outputs to magnetics.
50	TXN	AO	Transmit Data: 100Base-TX or 10Base-T differential transmit outputs to magnetics.
55	RXP	AI	Receive Data: 100Base-TX or 10Base-T differential receive inputs from magnetics.
54	RXN	AI	Receive Data: 100Base-TX or 10Base-T differential receive inputs from magnetics.

Table 3.7 Analog References

PIN NO.	SIGNAL NAME	TYPE	DESCRIPTION
59	EXRES1	AI	Connects to reference resistor of value 12.4K-Ohm, 1% connected to digital GND.

Table 3.8 Analog Test Bus

PIN NO.	SIGNAL NAME	TYPE	DESCRIPTION
56	NC2	AI/O	No Connect

Table 3.9 Power Signals

PIN NO.	SIGNAL NAME	TYPE	DESCRIPTION
53	AVDD1	Power	+3.3V Analog Power
57	AVDD2	Power	+3.3V Analog Power
61	AVDD3	Power	+3.3V Analog Power
63	AVDD4	Power	+3.3V Analog Power
49	AVSS1	Power	Analog Ground
52	AVSS2	Power	Analog Ground
58	AVSS3	Power	Analog Ground

Table 3.9 Power Signals (continued)

PIN NO.	SIGNAL NAME	TYPE	DESCRIPTION
60	AVSS4	Power	Analog Ground
62	AVSS5	Power	Analog Ground
13	VREG	Power	+3.3V Internal Regulator Input Voltage
14	VDD_CORE	Power	+1.8V Ring (Core voltage) - required for capacitance connection.
8	VDD1	Power	+3.3V Digital Power
18	VDD2	Power	+3.3V Digital Power
43	VDD3	Power	+3.3V Digital Power
7	VSS1	Power	Digital Ground (GND)
15	VSS2	Power	Digital Ground (GND)
21	VSS3	Power	Digital Ground (GND)
24	VSS4	Power	Digital Ground (GND)
28	VSS5	Power	Digital Ground (GND)
36	VSS6	Power	Digital Ground (GND)
40	VSS7	Power	Digital Ground (GND)

Chapter 4 Architecture Details

4.1 Top Level Functional Architecture

Functionally, the PHY can be divided into the following sections:

- 100Base-TX transmit and receive
- 10Base-T transmit and receive
- MII interface to the controller
- Auto-negotiation to automatically determine the best speed and duplex possible
- Management Control to read status registers and write control registers

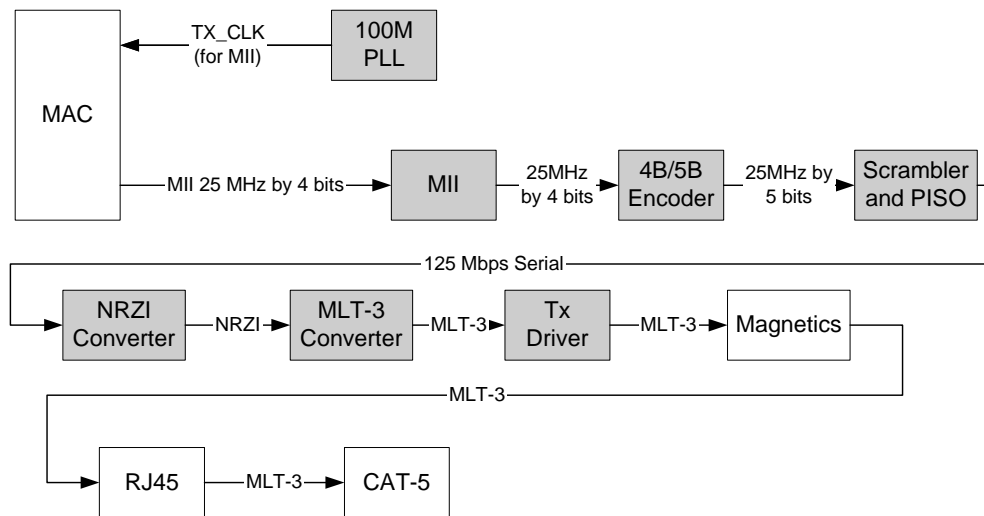

Figure 4.1 100Base-TX Data Path

4.2 100Base-TX Transmit

The data path of the 100Base-TX is shown in [Figure 4.1](#). Each major block is explained below.

4.2.1 100M Transmit Data across the MII

The MAC controller drives the transmit data onto the TXD bus and asserts TX_EN to indicate valid data. The data is latched by the PHY's MII block on the rising edge of TX_CLK. The data is in the form of 4-bit wide 25MHz data.

4.2.2 4B/5B Encoding

The transmit data passes from the MII block to the 4B/5B encoder. This block encodes the data from 4-bit nibbles to 5-bit symbols (known as "code-groups") according to [Table 4.1](#). Each 4-bit data-nibble is mapped to 16 of the 32 possible code-groups. The remaining 16 code-groups are either used for control information or are not valid.

The first 16 code-groups are referred to by the hexadecimal values of their corresponding data nibbles, 0 through F. The remaining code-groups are given letter designations with slashes on either side. For example, an IDLE code-group is /I/, a transmit error code-group is /H/, etc.

Datasheet

The encoding process may be bypassed by clearing bit 6 of register 31. When the encoding is bypassed the 5th transmit data bit is equivalent to TX_ER.

Note that encoding can be bypassed only when the MAC interface is configured to operate in MII mode.

Table 4.1 4B/5B Code Table

CODE GROUP	SYM	RECEIVER INTERPRETATION			TRANSMITTER INTERPRETATION		
11110	0	0	0000	DATA	0	0000	DATA
01001	1	1	0001		1	0001	
10100	2	2	0010		2	0010	
10101	3	3	0011		3	0011	
01010	4	4	0100		4	0100	
01011	5	5	0101		5	0101	
01110	6	6	0110		6	0110	
01111	7	7	0111		7	0111	
10010	8	8	1000		8	1000	
10011	9	9	1001		9	1001	
10110	A	A	1010		A	1010	
10111	B	B	1011		B	1011	
11010	C	C	1100		C	1100	
11011	D	D	1101		D	1101	
11100	E	E	1110		E	1110	
11101	F	F	1111		F	1111	
11111	I	IDLE			Sent after /T/R until TX_EN		
11000	J	First nibble of SSD, translated to "0101" following IDLE, else RX_ER			Sent for rising TX_EN		
10001	K	Second nibble of SSD, translated to "0101" following J, else RX_ER			Sent for rising TX_EN		
01101	T	First nibble of ESD, causes de-assertion of CRS if followed by /R/, else assertion of RX_ER			Sent for falling TX_EN		
00111	R	Second nibble of ESD, causes deassertion of CRS if following /T/, else assertion of RX_ER			Sent for falling TX_EN		
00100	H	Transmit Error Symbol			Sent for rising TX_ER		
00110	V	INVALID, RX_ER if during RX_DV			INVALID		
11001	V	INVALID, RX_ER if during RX_DV			INVALID		
00000	V	INVALID, RX_ER if during RX_DV			INVALID		
00001	V	INVALID, RX_ER if during RX_DV			INVALID		

Table 4.1 4B/5B Code Table (continued)

CODE GROUP	SYM	RECEIVER INTERPRETATION	TRANSMITTER INTERPRETATION
00010	V	INVALID, RX_ER if during RX_DV	INVALID
00011	V	INVALID, RX_ER if during RX_DV	INVALID
00101	V	INVALID, RX_ER if during RX_DV	INVALID
01000	V	INVALID, RX_ER if during RX_DV	INVALID
01100	V	INVALID, RX_ER if during RX_DV	INVALID
10000	V	INVALID, RX_ER if during RX_DV	INVALID

4.2.3 Scrambling

Repeated data patterns (especially the IDLE code-group) can have power spectral densities with large narrow-band peaks. Scrambling the data helps eliminate these peaks and spread the signal power more uniformly over the entire channel bandwidth. This uniform spectral density is required by FCC regulations to prevent excessive EMI from being radiated by the physical wiring.

The seed for the scrambler is generated from the PHY address, PHYAD[4:0], ensuring that in multiple-PHY applications, such as repeaters or switches, each PHY will have its own scrambler sequence.

The scrambler also performs the Parallel In Serial Out conversion (PISO) of the data.

4.2.4 NRZI and MLT3 Encoding

The scrambler block passes the 5-bit wide parallel data to the NRZI converter where it becomes a serial 125MHz NRZI data stream. The NRZI is encoded to MLT-3. MLT3 is a tri-level code where a change in the logic level represents a code bit "1" and the logic output remaining at the same level represents a code bit "0".

4.2.5 100M Transmit Driver

The MLT3 data is then passed to the analog transmitter, which launches the differential MLT-3 signal, on outputs TXP and TXN, to the twisted pair media via a 1:1 ratio isolation transformer. The 10Base-T and 100Base-TX signals pass through the same transformer so that common "magnetics" can be used for both. The transmitter drives into the 100Ω impedance of the CAT-5 cable. Cable termination and impedance matching require external components.

4.2.6 100M Phase Lock Loop (PLL)

The 100M PLL locks onto reference clock and generates the 125MHz clock used to drive the 125 MHz logic and the 100Base-Tx Transmitter.

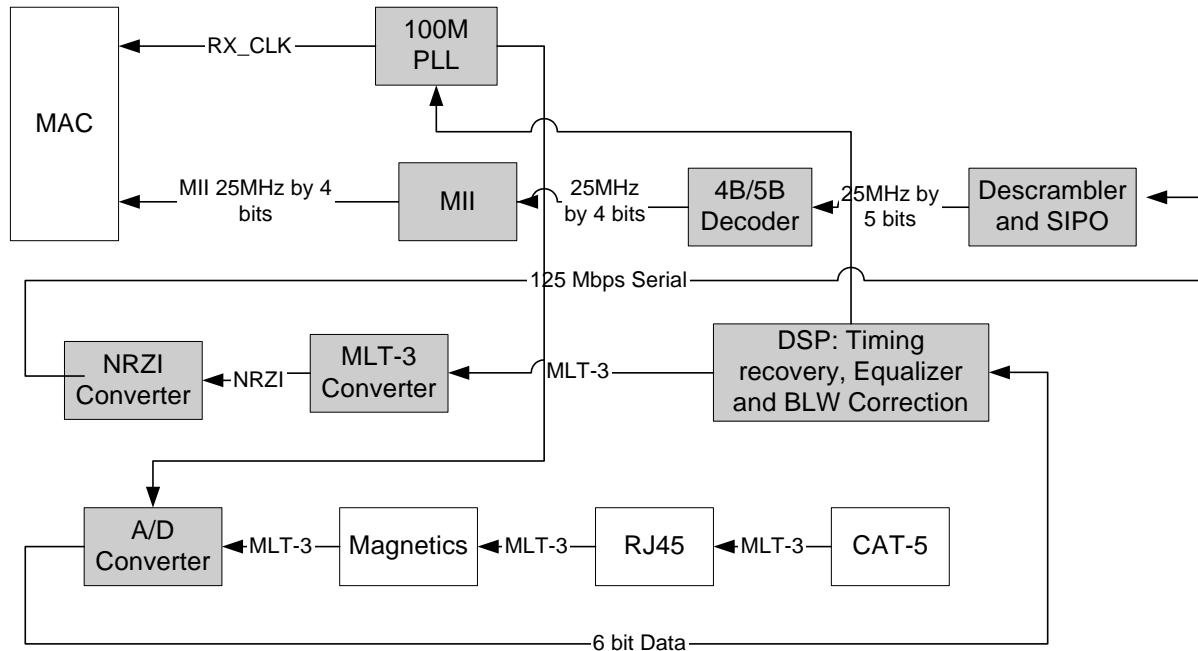

Figure 4.2 Receive Data Path

4.3 100Base-TX Receive

The receive data path is shown in [Figure 4.2](#). Detailed descriptions are given below.

4.3.1 100M Receive Input

The MLT-3 from the cable is fed into the PHY (on inputs RXP and RXN) via a 1:1 ratio transformer. The ADC samples the incoming differential signal at a rate of 125M samples per second. Using a 64-level quantizer it generates 6 digital bits to represent each sample. The DSP adjusts the gain of the ADC according to the observed signal levels such that the full dynamic range of the ADC can be used.

4.3.2 Equalizer, Baseline Wander Correction and Clock and Data Recovery

The 6 bits from the ADC are fed into the DSP block. The equalizer in the DSP section compensates for phase and amplitude distortion caused by the physical channel consisting of magnetics, connectors, and CAT-5 cable. The equalizer can restore the signal for any good-quality CAT-5 cable between 1m and 150m.

If the DC content of the signal is such that the low-frequency components fall below the low frequency pole of the isolation transformer, then the droop characteristics of the transformer will become significant and Baseline Wander (BLW) on the received signal will result. To prevent corruption of the received data, the PHY corrects for BLW and can receive the ANSI X3.263-1995 FDDI TP-PMD defined "killer packet" with no bit errors.

The 100M PLL generates multiple phases of the 125MHz clock. A multiplexer, controlled by the timing unit of the DSP, selects the optimum phase for sampling the data. This is used as the received recovered clock. This clock is used to extract the serial data from the received signal.

4.3.3 NRZI and MLT-3 Decoding

The DSP generates the MLT-3 recovered levels that are fed to the MLT-3 converter. The MLT-3 is then converted to an NRZI data stream.

4.3.4 Descrambling

The descrambler performs an inverse function to the scrambler in the transmitter and also performs the Serial In Parallel Out (SIPO) conversion of the data.

During reception of IDLE (/I/) symbols, the descrambler synchronizes its descrambler key to the incoming stream. Once synchronization is achieved, the descrambler locks on this key and is able to descramble incoming data.

Special logic in the descrambler ensures synchronization with the remote PHY by searching for IDLE symbols within a window of 4000 bytes (40us). This window ensures that a maximum packet size of 1514 bytes, allowed by the IEEE 802.3 standard, can be received with no interference. If no IDLE-symbols are detected within this time-period, receive operation is aborted and the descrambler re-starts the synchronization process.

The descrambler can be bypassed by setting bit 0 of register 31.

4.3.5 Alignment

The de-scrambled signal is then aligned into 5-bit code-groups by recognizing the /J/K/ Start-of-Stream Delimiter (SSD) pair at the start of a packet. Once the code-word alignment is determined, it is stored and utilized until the next start of frame.

4.3.6 5B/4B Decoding

The 5-bit code-groups are translated into 4-bit data nibbles according to the 4B/5B table. The translated data is presented on the RXD[3:0] signal lines. The SSD, /J/K/, is translated to "0101 0101" as the first 2 nibbles of the MAC preamble. Reception of the SSD causes the PHY to assert the RX_DV signal, indicating that valid data is available on the RXD bus. Successive valid code-groups are translated to data nibbles. Reception of either the End of Stream Delimiter (ESD) consisting of the /T/R/ symbols, or at least two /I/ symbols causes the PHY to de-assert carrier sense and RX_DV.

These symbols are not translated into data.

The decoding process may be bypassed by clearing bit 6 of register 31. When the decoding is bypassed the 5th receive data bit is driven out on RX_ER/RXD4. Decoding may be bypassed only when the MAC interface is in MII mode.

4.3.7 Receive Data Valid Signal

The Receive Data Valid signal (RX_DV) indicates that recovered and decoded nibbles are being presented on the RXD[3:0] outputs synchronous to RX_CLK. RX_DV becomes active after the /J/K/ delimiter has been recognized and RXD is aligned to nibble boundaries. It remains active until either the /T/R/ delimiter is recognized or link test indicates failure or SIGDET becomes false.

RX_DV is asserted when the first nibble of translated /J/K/ is ready for transfer over the Media Independent Interface (MII).

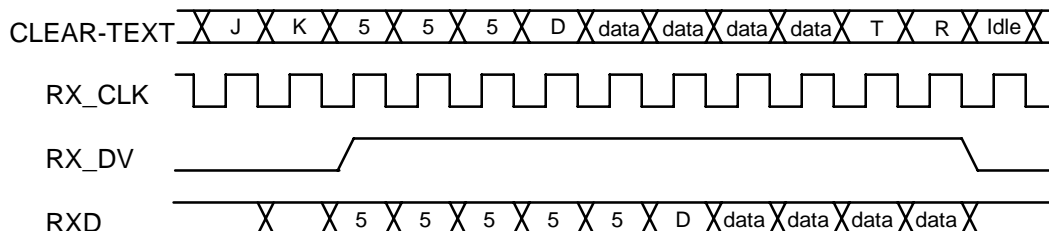

Figure 4.3 Relationship Between Received Data and Some MII Signals

4.3.8 Receiver Errors

During a frame, unexpected code-groups are considered receive errors. Expected code groups are the DATA set (0 through F), and the /T/R/ (ESD) symbol pair. When a receive error occurs, the RX_ER signal is asserted and arbitrary data is driven onto the RXD[3:0] lines. Should an error be detected during the time that the /J/K/ delimiter is being decoded (bad SSD error), RX_ER is asserted true and the value '1110' is driven onto the RXD[3:0] lines. Note that the Valid Data signal is not yet asserted when the bad SSD error occurs.

4.3.9 100M Receive Data across the MII

The 4-bit data nibbles are sent to the MII block. These data nibbles are clocked to the controller at a rate of 25MHz. The controller samples the data on the rising edge of RX_CLK. To ensure that the setup and hold requirements are met, the nibbles are clocked out of the PHY on the falling edge of RX_CLK. RX_CLK is the 25MHz output clock for the MII bus. It is recovered from the received data to clock the RXD bus. If there is no received signal, it is derived from the system reference clock (CLKIN).

When tracking the received data, RX_CLK has a maximum jitter of 0.8ns (provided that the jitter of the input clock, CLKIN, is below 100ps).

4.4 10Base-T Transmit

Data to be transmitted comes from the MAC layer controller. The 10Base-T transmitter receives 4-bit nibbles from the MII at a rate of 2.5MHz and converts them to a 10Mbps serial data stream. The data stream is then Manchester-encoded and sent to the analog transmitter, which drives a signal onto the twisted pair via the external magnetics.

The 10M transmitter uses the following blocks:

- MII (digital)
- TX 10M (digital)
- 10M Transmitter (analog)
- 10M PLL (analog)

4.4.1 10M Transmit Data across the MII

The MAC controller drives the transmit data onto the TXD BUS. When the controller has driven TX_EN high to indicate valid data, the data is latched by the MII block on the rising edge of TX_CLK. The data is in the form of 4-bit wide 2.5MHz data.

In order to comply with legacy 10Base-T MAC/Controllers, in Half-duplex mode the PHY loops back the transmitted data, on the receive path. This does not confuse the MAC/Controller since the COL signal is not asserted during this time. The PHY also supports the SQE (Heartbeat) signal. See [Section 5.4.2, "Collision Detect," on page 43](#) for more details.

4.4.2 Manchester Encoding

The 4-bit wide data is sent to the TX10M block. The nibbles are converted to a 10Mbps serial NRZI data stream. The 10M PLL locks onto the external clock or internal oscillator and produces a 20MHz clock. This is used to Manchester encode the NRZ data stream. When no data is being transmitted (TX_EN is low, the TX10M block outputs Normal Link Pulses (NLPs) to maintain communications with the remote link partner.

4.4.3 10M Transmit Drivers

The Manchester encoded data is sent to the analog transmitter where it is shaped and filtered before being driven out as a differential signal across the TXP and TXN outputs.

4.5 10Base-T Receive

The 10Base-T receiver gets the Manchester- encoded analog signal from the cable via the magnetics. It recovers the receive clock from the signal and uses this clock to recover the NRZI data stream. This 10M serial data is converted to 4-bit data nibbles which are passed to the controller across the MII at a rate of 2.5MHz.

This 10M receiver uses the following blocks:

- Filter and SQUELCH (analog)
- 10M PLL (analog)
- RX 10M (digital)
- MII (digital)

4.5.1 10M Receive Input and Squelch

The Manchester signal from the cable is fed into the PHY (on inputs RXP and RXN) via 1:1 ratio magnetics. It is first filtered to reduce any out-of-band noise. It then passes through a SQUELCH circuit. The SQUELCH is a set of amplitude and timing comparators that normally reject differential voltage levels below 300mV and detect and recognize differential voltages above 585mV.

4.5.2 Manchester Decoding

The output of the SQUELCH goes to the RX10M block where it is validated as Manchester encoded data. The polarity of the signal is also checked. If the polarity is reversed (local RXP is connected to RXN of the remote partner and vice versa), then this is identified and corrected. The reversed condition is indicated by the flag "XPOL", bit 4 in register 27. The 10M PLL is locked onto the received Manchester signal and from this, generates the received 20MHz clock. Using this clock, the Manchester encoded data is extracted and converted to a 10MHz NRZI data stream. It is then converted from serial to 4-bit wide parallel data.

The RX10M block also detects valid 10Base-T IDLE signals - Normal Link Pulses (NLPs) - to maintain the link.

4.5.3 10M Receive Data across the MII

The 4 bit data nibbles are sent to the MII block. In MII mode, these data nibbles are valid on the rising edge of the 2.5 MHz RX_CLK.

4.5.4 Jabber detection

Jabber is a condition in which a station transmits for a period of time longer than the maximum permissible packet length, usually due to a fault condition, that results in holding the TX_EN input for a long period. Special logic is used to detect the jabber state and abort the transmission to the line, within 45ms. Once TX_EN is deasserted, the logic resets the jabber condition.

Bit 1.1 indicates that a jabber condition was detected.

4.6 MAC Interface

The MII (Media Independent Interface) block is responsible for the communication with the controller. Special sets of hand-shake signals are used to indicate that valid received/transmitted data is present on the 4 bit receive/transmit bus.

Datasheet

4.6.1 MII

The MII includes 16 interface signals:

- transmit data - TXD[3:0]
- transmit strobe - TX_EN
- transmit clock - TX_CLK
- transmit error - TX_ER/TXD4
- receive data - RXD[3:0]
- receive strobe - RX_DV
- receive clock - RX_CLK
- receive error - RX_ER/RXD4
- collision indication - COL
- carrier sense - CRS

In MII mode, on the transmit path, the PHY drives the transmit clock, TX_CLK, to the controller. The controller synchronizes the transmit data to the rising edge of TX_CLK. The controller drives TX_EN high to indicate valid transmit data. The controller drives TX_ER high when a transmit error is detected.

On the receive path, the PHY drives both the receive data, RXD[3:0], and the RX_CLK signal. The controller clocks in the receive data on the rising edge of RX_CLK when the PHY drives RX_DV high. The PHY drives RX_ER high when a receive error is detected.

4.7 Auto-negotiation

The purpose of the Auto-negotiation function is to automatically configure the PHY to the optimum link parameters based on the capabilities of its link partner. Auto-negotiation is a mechanism for exchanging configuration information between two link-partners and automatically selecting the highest performance mode of operation supported by both sides. Auto-negotiation is fully defined in clause 28 of the IEEE 802.3 specification.

Once auto-negotiation has completed, information about the resolved link can be passed back to the controller via the Serial Management Interface (SMI). The results of the negotiation process are reflected in the Speed Indication bits in register 31, as well as the Link Partner Ability Register (Register 5).

The auto-negotiation protocol is a purely physical layer activity and proceeds independently of the MAC controller.

The advertised capabilities of the PHY are stored in register 4 of the SMI registers. The default advertised by the PHY is determined by user-defined on-chip signal options.

The following blocks are activated during an Auto-negotiation session:

- Auto-negotiation (digital)
- 100M ADC (analog)
- 100M PLL (analog)
- 100M equalizer/BLW/clock recovery (DSP)
- 10M SQUELCH (analog)
- 10M PLL (analog)
- 10M Transmitter (analog)

When enabled, auto-negotiation is started by the occurrence of one of the following events:

- Hardware reset
- Software reset

- Power-down reset
- Link status down
- Setting register 0, bit 9 high (auto-negotiation restart)

On detection of one of these events, the PHY begins auto-negotiation by transmitting bursts of Fast Link Pulses (FLP). These are bursts of link pulses from the 10M transmitter. They are shaped as Normal Link Pulses and can pass uncorrupted down CAT-3 or CAT-5 cable. A Fast Link Pulse Burst consists of up to 33 pulses. The 17 odd-numbered pulses, which are always present, frame the FLP burst. The 16 even-numbered pulses, which may be present or absent, contain the data word being transmitted. Presence of a data pulse represents a “1”, while absence represents a “0”.

The data transmitted by an FLP burst is known as a “Link Code Word.” These are defined fully in IEEE 802.3 clause 28. In summary, the PHY advertises 802.3 compliance in its selector field (the first 5 bits of the Link Code Word). It advertises its technology ability according to the bits set in register 4 of the SMI registers.

There are 4 possible matches of the technology abilities. In the order of priority these are:

- 100M Full Duplex (Highest priority)
- 100M Half Duplex
- 10M Full Duplex
- 10M Half Duplex

If the full capabilities of the PHY are advertised (100M, Full Duplex), and if the link partner is capable of 10M and 100M, then auto-negotiation selects 100M as the highest performance mode. If the link partner is capable of Half and Full duplex modes, then auto-negotiation selects Full Duplex as the highest performance operation.

Once a capability match has been determined, the link code words are repeated with the acknowledge bit set. Any difference in the main content of the link code words at this time will cause auto-negotiation to re-start. Auto-negotiation will also re-start if not all of the required FLP bursts are received.

The capabilities advertised during auto-negotiation by the PHY are initially determined by the logic levels latched on the MODE[2:0] bus after reset completes. This bus can also be used to disable auto-negotiation on power-up.

Writing register 4 bits [8:5] allows software control of the capabilities advertised by the PHY. Writing register 4 does not automatically re-start auto-negotiation. Register 0, bit 9 must be set before the new abilities will be advertised. Auto-negotiation can also be disabled via software by clearing register 0, bit 12.

The LAN83C185 does not support “Next Page” capability.

4.7.1 Parallel Detection

If the LAN83C185 is connected to a device lacking the ability to auto-negotiate (i.e. no FLPs are detected), it is able to determine the speed of the link based on either 100M MLT-3 symbols or 10M Normal Link Pulses. In this case the link is presumed to be Half Duplex per the IEEE standard. This ability is known as “Parallel Detection. This feature ensures interoperability with legacy link partners. If a link is formed via parallel detection, then bit 0 in register 6 is cleared to indicate that the Link Partner is not capable of auto-negotiation. The controller has access to this information via the management interface. If a fault occurs during parallel detection, bit 4 of register 6 is set.

Register 5 is used to store the Link Partner Ability information, which is coded in the received FLPs. If the Link Partner is not auto-negotiation capable, then register 5 is updated after completion of parallel detection to reflect the speed capability of the Link Partner.

4.7.2 Re-starting Auto-negotiation

Auto-negotiation can be re-started at any time by setting register 0, bit 9. Auto-negotiation will also re-start if the link is broken at any time. A broken link is caused by signal loss. This may occur because of a cable break, or because of an interruption in the signal transmitted by the Link Partner. Auto-negotiation resumes in an attempt to determine the new link configuration.

If the management entity re-starts Auto-negotiation by writing to bit 9 of the control register, the LAN83C185 will respond by stopping all transmission/receiving operations. Once the break_link_timer is done, in the Auto-negotiation state-machine (approximately 1200ms) the auto-negotiation will re-start. The Link Partner will have also dropped the link due to lack of a received signal, so it too will resume auto-negotiation.

4.7.3 Disabling Auto-negotiation

Auto-negotiation can be disabled by setting register 0, bit 12 to zero. The device will then force its speed of operation to reflect the information in register 0, bit 13 (speed) and register 0, bit 8 (duplex). The speed and duplex bits in register 0 should be ignored when auto-negotiation is enabled.

4.7.4 Half vs. Full Duplex

Half Duplex operation relies on the CSMA/CD (Carrier Sense Multiple Access / Collision Detect) protocol to handle network traffic and collisions. In this mode, the carrier sense signal, CRS, responds to both transmit and receive activity. In this mode, if data is received while the PHY is transmitting, a collision results.

In Full Duplex mode, the PHY is able to transmit and receive data simultaneously. In this mode, CRS responds only to receive activity. The CSMA/CD protocol does not apply and collision detection is disabled.

4.8 PHY Management Control

The Management Control module includes 3 blocks:

- Serial Management Interface (SMI)
- Management Registers Set
- Interrupt

4.8.1 Serial Management Interface (SMI)

The Serial Management Interface is used to control the LAN83C185 and obtain its status. This interface supports registers 0 through 6 as required by Clause 22 of the 802.3 standard, as well as "vendor-specific" registers 16 to 31 allowed by the specification. Non-supported registers (7 to 15) will be read as hexadecimal "FFFF".

At the system level there are 2 signals, MDIO and MDC where MDIO is bi-directional open-drain and MDC is the clock.

A special feature (enabled by register 17 bit 3) forces the PHY to disregard the PHY-Address in the SMI packet causing the PHY to respond to any address. This feature is useful in multi-PHY applications and in production testing, where the same register can be written in all the PHYs using a single write transaction.

The MDC signal is an aperiodic clock provided by the station management controller (SMC). The MDIO signal receives serial data (commands) from the controller SMC, and sends serial data (status) to the SMC. The minimum time between edges of the MDC is 160 ns. There is no maximum time between edges.

The minimum cycle time (time between two consecutive rising or two consecutive falling edges) is 400 ns. These modest timing requirements allow this interface to be easily driven by the I/O port of a microcontroller.

The data on the MDIO line is latched on the rising edge of the MDC. The frame structure and timing of the data is shown in [Figure 4.4](#) and [Figure 4.5](#).

The timing relationships of the MDIO signals are further described in [Section 6.1, "Serial Management Interface \(SMI\) Timing,"](#) on page 50.

Read Cycle

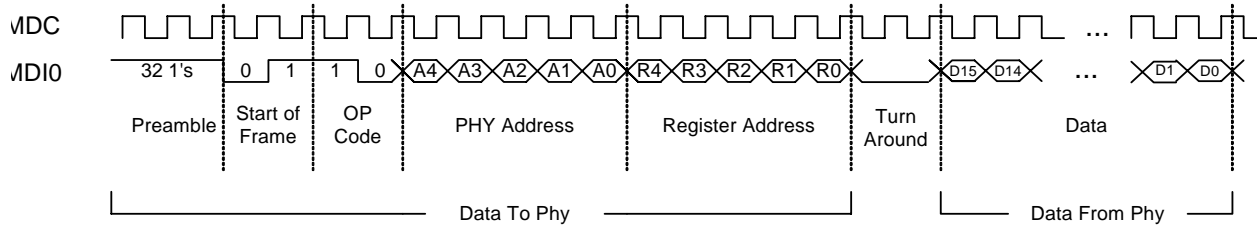

Figure 4.4 MDIO Timing and Frame Structure - READ Cycle

Write Cycle

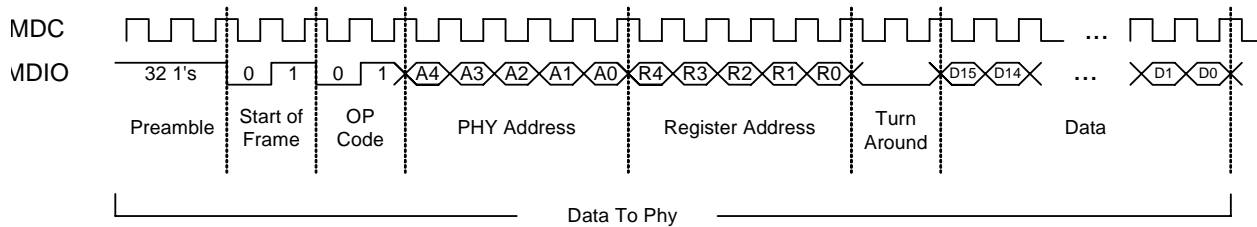

Figure 4.5 MDIO Timing and Frame Structure - WRITE Cycle

Chapter 5 Registers

Revision 0.8 (06-12-08)

Table 5.1 Control Register: Register 0 (Basic)

15	14	13	12	11	10	9	8	7	6	5	4	3	2	1	0
Reset	Loopback	Speed Select	A/N Enable	Power Down	Isolate	Restart A/N	Duplex Mode	Collision Test	Reserved						

Table 5.2 Status Register: Register 1 (Basic)

15	14	13	12	11	10	9	8	7	6	5	4	3	2	1	0
100Base-T4	100Base-TX Full Duplex	100Base-TX Half Duplex	10Base-T Full Duplex	10Base-T Half Duplex	Reserved					A/N Complete	Remote Fault	A/N Ability	Link Status	Jabber Detect	Extended Capability

Table 5.3 PHY ID 1 Register: Register 2 (Extended)

15	14	13	12	11	10	9	8	7	6	5	4	3	2	1	0
PHY ID Number (Bits 3-18 of the Organizationally Unique Identifier - OUI)															

Table 5.4 PHY ID 2 Register: Register 3 (Extended)

15	14	13	12	11	10	9	8	7	6	5	4	3	2	1	0
PHY ID Number (Bits 19-24 of the Organizationally Unique Identifier - OUI)						Manufacturer Model Number						Manufacturer Revision Number			

Table 5.5 Auto-Negotiation Advertisement: Register 4 (Extended)

15	14	13	12	11	10	9	8	7	6	5	4	3	2	1	0
Next Page	Reserved	Remote Fault	Reserved	Symmetric Pause Operation	Asymmetric Pause Operation	100Base-T4	100Base-TX Full Duplex	100Base-TX	10Base-T Full Duplex	10Base-T	IEEE 802.3 Selector Field				

27
 DATASHEET

SMSC LAN83C185

Table 5.6 Auto-Negotiation Link Partner Base Page Ability Register: Register 5 (Extended)

15	14	13	12	11	10	9	8	7	6	5	4	3	2	1	0
Next Page	Acknowledge	Remote Fault	Reserved		Pause	100Base-T4	100Base-TX Full Duplex	100Base-TX	10Base-T Full Duplex	10Base-T	IEEE 802.3 Selector Field				

Table 5.7 Auto-Negotiation Expansion Register: Register 6 (Extended)

15	14	13	12	11	10	9	8	7	6	5	4	3	2	1	0
Reserved										Parallel Detect Fault	Link Partner Next Page Able	Next Page Able	Page Received	Link Partner A/N Able	

Table 5.8 Auto-Negotiation Link Partner Next Page Transmit Register: Register 7 (Extended)

15	14	13	12	11	10	9	8	7	6	5	4	3	2	1	0
Reserved															

Note: Next Page capability is not supported.

Table 5.9 Register 8 (Extended)

15	14	13	12	11	10	9	8	7	6	5	4	3	2	1	0
IEEE Reserved															

Table 5.10 Register 9 (Extended)

15	14	13	12	11	10	9	8	7	6	5	4	3	2	1	0
IEEE Reserved															

Table 5.11 Register 10 (Extended)

15	14	13	12	11	10	9	8	7	6	5	4	3	2	1	0
IEEE Reserved															

Table 5.12 Register 11 (Extended)

15	14	13	12	11	10	9	8	7	6	5	4	3	2	1	0
IEEE Reserved															

Table 5.13 Register 12 (Extended)

15	14	13	12	11	10	9	8	7	6	5	4	3	2	1	0
IEEE Reserved															

Table 5.14 Register 13 (Extended)

15	14	13	12	11	10	9	8	7	6	5	4	3	2	1	0
IEEE Reserved															

Table 5.15 Register 14 (Extended)

15	14	13	12	11	10	9	8	7	6	5	4	3	2	1	0
IEEE Reserved															

Table 5.16 Register 15 (Extended)

15	14	13	12	11	10	9	8	7	6	5	4	3	2	1	0
IEEE Reserved															

Revision 0.8 (06-12-08)

29
 DATASHEET

SMSC LAN83C185

Table 5.17 Silicon Revision Register 16: Vendor-Specific

15	14	13	12	11	10	9	8	7	6	5	4	3	2	1	0
Reserved						Silicon Revision					Reserved				

Table 5.18 Mode Control/ Status Register 17: Vendor-Specific

15	14	13	12	11	10	9	8	7	6	5	4	3	2	1	0
Reserved	FASTRIP	EDPWRDOWN	Reserved	LOWSQEN	MDPREBP	FARLOOPBACK	FASTEST	Reserved			REFCLKEN	PHYADBP	Force Good Link Status	ENERGYON	Reserved

Table 5.19 Special Modes Register 18: Vendor-Specific

15	14	13	12	11	10	9	8	7	6	5	4	3	2	1	0
MIIMODE		CLKSELFREQ	DSPBP	SQBP	Reserved	PLLBP	ADCBP	MODE			PHYAD				

Table 5.20 Reserved Register 19: Vendor-Specific

15	14	13	12	11	10	9	8	7	6	5	4	3	2	1	0
Reserved															

Table 5.21 TSTCNTL Register 20: Vendor-Specific

15	14	13	12	11	10	9	8	7	6	5	4	3	2	1	0
READ	WRITE	Reserved			TEST MODE	READ ADDRESS					WRITE ADDRESS				

Table 5.22 TSTREAD2 Register 21: Vendor-Specific

15	14	13	12	11	10	9	8	7	6	5	4	3	2	1	0
READ_DATA															

Table 5.23 TSTREAD1 Register 22: Vendor-Specific

15	14	13	12	11	10	9	8	7	6	5	4	3	2	1	0
READ_DATA															

Table 5.24 TSTWRITE Register 23: Vendor-Specific

15	14	13	12	11	10	9	8	7	6	5	4	3	2	1	0
WRITE_DATA															

Table 5.25 Register 24: Vendor-Specific

15	14	13	12	11	10	9	8	7	6	5	4	3	2	1	0
Reserved															

Table 5.26 Register 25: Vendor-Specific

15	14	13	12	11	10	9	8	7	6	5	4	3	2	1	0
Reserved															

Table 5.27 Register 26: Vendor-Specific

15	14	13	12	11	10	9	8	7	6	5	4	3	2	1	0
Reserved															

Table 5.28 Special Control/Status Indications Register 27: Vendor-Specific

15	14	13	12	11	10	9	8	7	6	5	4	3	2	1	0
Reserved			SWRST_FAST	SQEOFF	VCOFF_LP	Reserved	Reserved	Reserved	Reserved	Reserved	XPOL	AUTONEGS			

Table 5.29 Special Internal Testability Control Register 28: Vendor-Specific

15	14	13	12	11	10	9	8	7	6	5	4	3	2	1	0
Reserved															

Table 5.30 Interrupt Source Flags Register 29: Vendor-Specific

15	14	13	12	11	10	9	8	7	6	5	4	3	2	1	0
Reserved							INT7	INT6	INT5	INT4	INT3	INT2	INT1	Reserved	

Table 5.31 Interrupt Mask Register 30: Vendor-Specific

15	14	13	12	11	10	9	8	7	6	5	4	3	2	1	0
Reserved								Mask Bits							

Table 5.32 PHY Special Control/Status Register 31: Vendor-Specific

15	14	13	12	11	10	9	8	7	6	5	4	3	2	1	0
Reserved	Reserved	Special	Autodone	Reserved	GPO2	GPO1	GPO0	Enable 4B5B	Reserved	Speed Indication			Reserved	Scramble Disable	

Datasheet

5.1 SMI Register Mapping

The following registers are supported (register numbers are in decimal):

Table 5.33 SMI Register Mapping

REGISTER #	DESCRIPTION	GROUP
0	Basic Control Register	Basic
1	Basic Status Register	Basic
2	PHY Identifier 1	Extended
3	PHY Identifier 2	Extended
4	Auto-Negotiation Advertisement Register	Extended
5	Auto-Negotiation Link Partner Ability Register	Extended
6	Auto-Negotiation Expansion Register	Extended
16	Silicon Revision Register	Vendor-specific
17	Mode Control/Status Register	Vendor-specific
18	Special Modes	Vendor-specific
20	TSTCNTL – Testability/Configuration Control	Vendor-specific
21	TSTREAD1 – Testability data Read for LSB	Vendor-specific
22	TSTREAD2 – Testability data Read for MSB	Vendor-specific
23	TSTWRITE – Testability/Configuration data Write	Vendor-specific
27	Control / Status Indication Register	Vendor-specific
28	Special internal testability controls	Vendor-specific
29	Interrupt Source Register	Vendor-specific
30	Interrupt Mask Register	Vendor-specific
31	PHY Special Control/Status Register	Vendor-specific

5.2 SMI Register Format

The mode key is as follows:

- RW = read/write,
- SC = self clearing,
- WO = write only,
- RO = read only,
- LH = latch high, clear on read of register,
- LL = latch low, clear on read of register,
- NASR = Not Affected by Software Reset

Table 5.34 Register 0 - Basic Control

ADDRESS	NAME	DESCRIPTION	MODE	DEFAULT
0.15	Reset	1 = software reset. Bit is self-clearing. For best results, when setting this bit do not set other bits in this register.	RW/SC	0
0.14	Loopback	1 = loopback mode, 0 = normal operation	RW	0
0.13	Speed Select	1 = 100Mbps, 0 = 10Mbps. Ignored if Auto Negotiation is enabled (0.12 = 1).	RW	Set by MODE[2:0] bus
0.12	Auto-Negotiation Enable	1 = enable auto-negotiate process (overrides 0.13 and 0.8) 0 = disable auto-negotiate process	RW	Set by MODE[2:0] bus
0.11	Power Down	1 = General power down mode, 0 = normal operation	RW	0
0.10	Isolate	1 = electrical isolation of PHY from MII 0 = normal operation	RW	Set by MODE[2:0] bus
0.9	Restart Auto-Negotiate	1 = restart auto-negotiate process 0 = normal operation. Bit is self-clearing.	RW/SC	0
0.8	Duplex Mode	1 = Full duplex, 0 = Half duplex. Ignored if Auto Negotiation is enabled (0.12 = 1).	RW	Set by MODE[2:0] bus
0.7	Collision Test	1 = enable COL test, 0 = disable COL test	RW	0
0.6:0	Reserved		RO	0

Table 5.35 Register 1 - Basic Status

ADDRESS	NAME	DESCRIPTION	MODE	DEFAULT
1.15	100Base-T4	1 = T4 able, 0 = no T4 ability	RO	0
1.14	100Base-TX Full Duplex	1 = TX with full duplex, 0 = no TX full duplex ability	RO	1
1.13	100Base-TX Half Duplex	1 = TX with half duplex, 0 = no TX half duplex ability	RO	1
1.12	10Base-T Full Duplex	1 = 10Mbps with full duplex 0 = no 10Mbps with full duplex ability	RO	1
1.11	10Base-T Half Duplex	1 = 10Mbps with half duplex 0 = no 10Mbps with half duplex ability	RO	1
1.10:6	Reserved			
1.5	Auto-Negotiate Complete	1 = auto-negotiate process completed 0 = auto-negotiate process not completed	RO	0
1.4	Remote Fault	1 = remote fault condition detected 0 = no remote fault	RO/LH	0

Table 5.35 Register 1 - Basic Status (continued)

ADDRESS	NAME	DESCRIPTION	MODE	DEFAULT
1.3	Auto-Negotiate Ability	1 = able to perform auto-negotiation function 0 = unable to perform auto-negotiation function	RO	1
1.2	Link Status	1 = link is up, 0 = link is down	RO/ LL	0
1.1	Jabber Detect	1 = jabber condition detected 0 = no jabber condition detected	RO/ LH	0
1.0	Extended Capabilities	1 = supports extended capabilities registers 0 = does not support extended capabilities registers	RO	1

Table 5.36 Register 2 - PHY Identifier 1

ADDRESS	NAME	DESCRIPTION	MODE	DEFAULT
2.15:0	PHY ID Number	Assigned to the 3rd through 18th bits of the Organizationally Unique Identifier (OUI), respectively. OUI=00800Fh	RW	0007h

Table 5.37 Register 3 - PHY Identifier 2

ADDRESS	NAME	DESCRIPTION	MODE	DEFAULT
3.15:10	PHY ID Number	Assigned to the 19 th through 24 th bits of the OUI.	RW	C0h
3.9:4	Model Number	Six-bit manufacturer's model number.	RW	0Ah
3.3:0	Revision Number	Four-bit manufacturer's revision number.	RW	1h

Table 5.38 Register 4 - Auto Negotiation Advertisement

ADDRESS	NAME	DESCRIPTION	MODE	DEFAULT
4.15	Next Page	1 = next page capable, 0 = no next page ability This Phy does not support next page ability.	RO	0
4.14	Reserved		RO	0
4.13	Remote Fault	1 = remote fault detected, 0 = no remote fault	RW	0
4.12	Reserved			
4.11:10	Pause Operation	00 = No PAUSE 01 = Asymmetric PAUSE toward link partner 10 = Symmetric PAUSE 11 = Both Symmetric PAUSE and Asymmetric PAUSE toward local device	R/W	00
4.9	100Base-T4	1 = T4 able, 0 = no T4 ability This Phy does not support 100Base-T4.	RO	0

Table 5.38 Register 4 - Auto Negotiation Advertisement (continued)

ADDRESS	NAME	DESCRIPTION	MODE	DEFAULT
4.8	100Base-TX Full Duplex	1 = TX with full duplex, 0 = no TX full duplex ability	RW	Set by MODE[2:0] bus
4.7	100Base-TX	1 = TX able, 0 = no TX ability	RW	1
4.6	10Base-T Full Duplex	1 = 10Mbps with full duplex 0 = no 10Mbps with full duplex ability	RW	Set by MODE[2:0] bus
4.5	10Base-T	1 = 10Mbps able, 0 = no 10Mbps ability	RW	Set by MODE[2:0] bus
4.4:0	Selector Field	[00001] = IEEE 802.3	RW	00001

Table 5.39 Register 5 - Auto Negotiation Link Partner Ability

ADDRESS	NAME	DESCRIPTION	MODE	DEFAULT
5.15	Next Page	1 = "Next Page" capable, 0 = no "Next Page" ability This Phy does not support next page ability.	RO	0
5.14	Acknowledge	1 = link code word received from partner 0 = link code word not yet received	RO	0
5.13	Remote Fault	1 = remote fault detected, 0 = no remote fault	RO	0
5.12:11	Reserved		RO	0
5.10	Pause Operation	1 = Pause Operation is supported by remote MAC, 0 = Pause Operation is not supported by remote MAC	RO	0
5.9	100Base-T4	1 = T4 able, 0 = no T4 ability. This Phy does not support T4 ability.	RO	0
5.8	100Base-TX Full Duplex	1 = TX with full duplex, 0 = no TX full duplex ability	RO	0
5.7	100Base-TX	1 = TX able, 0 = no TX ability	RO	0
5.6	10Base-T Full Duplex	1 = 10Mbps with full duplex 0 = no 10Mbps with full duplex ability	RO	0
5.5	10Base-T	1 = 10Mbps able, 0 = no 10Mbps ability	RO	0
5.4:0	Selector Field	[00001] = IEEE 802.3	RO	00001

Table 5.40 Register 6 - Auto Negotiation Expansion

ADDRESS	NAME	DESCRIPTION	MODE	DEFAULT
6.15:5	Reserved		RO	0
6.4	Parallel Detection Fault	1 = fault detected by parallel detection logic 0 = no fault detected by parallel detection logic	RO/ LH	0
6.3	Link Partner Next Page Able	1 = link partner has next page ability 0 = link partner does not have next page ability	RO	0
6.2	Next Page Able	1 = local device has next page ability 0 = local device does not have next page ability	RO	0
6.1	Page Received	1 = new page received 0 = new page not yet received	RO/ LH	0
6.0	Link Partner Auto-Negotiation Able	1 = link partner has auto-negotiation ability 0 = link partner does not have auto-negotiation ability	RO	0

Table 5.41 Register 16 - Silicon Revision

ADDRESS	NAME	DESCRIPTION	MODE	DEFAULT
16.15:10	Reserved		RO	0
16.9:6	Silicon Revision	Four-bit silicon revision identifier.	RO	0001
16.5:0	Reserved		RO	0

Table 5.42 Register 17 - Mode Control/Status

ADDRESS	NAME	DESCRIPTION	MODE	DEFAULT
17.15	Reserved	Write as 0; ignore on read.	RW	0
17.14	FASTRIP	10Base-T fast mode: 0 = normal operation 1 = Reserved Must be left at 0	RW, NASR	0
17.13	EDPWRDOWN	Enable the Energy Detect Power-Down mode: 0 = Energy Detect Power-Down is disabled 1 = Energy Detect Power-Down is enabled	RW	0
17.12	Reserved	Write as 0, ignore on read	RW	0
17.11	LOWSQEN	The Low_Squelch signal is equal to LOWSQEN AND EDPWRDOWN. Low_Squelch = 1 implies a lower threshold (more sensitive). Low_Squelch = 0 implies a higher threshold (less sensitive).	RW	0
17.10	MDPREBP	Management Data Preamble Bypass: 0 – detect SMI packets with Preamble 1 – detect SMI packets without preamble	RW	0
17.9	Reserved	Reserved Must be left at 0	RW	0

Table 5.42 Register 17 - Mode Control/Status (continued)

ADDRESS	NAME	DESCRIPTION	MODE	DEFAULT
17.8	FASTEST	Auto-Negotiation Test Mode 0 = normal operation 1 = activates test mode	RW	0
17.7:5	Reserved	Write as 0, ignore on read.		
17.4	Reserved	Reserved Must be left at 0	RW	0
17.3	PHYADBP	1 = PHY disregards PHY address in SMI access write.	RW	0
17.2	Force Good Link Status	0 = normal operation; 1 = force 100TX- link active; Note: This bit should be set only during lab testing	RW	0
17.1	ENERGYON	ENERGYON – indicates whether energy is detected on the line (see Section 5.4.5.2, "Energy Detect Power-Down," on page 43); it goes to "0" if no valid energy is detected within 256ms. Reset to "1" by hardware reset, unaffected by SW reset.	RO	1
17.0	Reserved	Write as "0". Ignore on read.	RW	0

Table 5.43 Register 18 - Special Modes

ADDRESS	NAME	DESCRIPTION	MODE	DEFAULT
18.15:14	MIIMODE	MII Mode: set the mode of the MII: 0 – MII interface. 1 – Reserved	RW, NASR	
18.13	CLKSELFREQ	Clock In Selected Frequency. Set the requested input clock frequency. This bit drives signal that goes to external logic of the Phy and select the desired frequency of the input clock: 0 – the clock frequency is 25MHz 1 – Reserved	RO, NASR	
18.12	DSPBP	DSP Bypass mode. Used only in special lab tests.	RW, NASR	0
18.11	SQBP	SQUELCH Bypass mode.	RW, NASR	0
18.10	Reserved		RW, NASR	
18.9	PLLBP	PLL Bypass mode.	RW, NASR	
18.8	ADCBP	ADC Bypass mode.	RW, NASR	
18.7:5	MODE	PHY Mode of operation. Refer to Section 5.4.9.2, "Mode Bus – MODE[2:0]," on page 46 for more details.	RW, NASR	

Table 5.43 Register 18 - Special Modes (continued)

ADDRESS	NAME	DESCRIPTION	MODE	DEFAULT
18.4:0	PHYAD	PHY Address. The PHY Address is used for the SMI address and for the initialization of the Cipher (Scrambler) key. Refer to Section 5.4.9.1, "Physical Address Bus - PHYAD[4:0]," on page 45 for more details.	RW, NASR	PHYAD

Table 5.44 Register 20 - TSTCNTL

ADDRESS	NAME	DESCRIPTION	MODE	DEFAULT
20.15	READ	When setting this bit to "1", the content of the register that is selected by the READ ADDRESS will be latched to the TSTREAD1/2 registers. This bit is self-cleared.	RW	0
20.14	WRITE	When setting this bit to "1", the register that is selected by the WRITE ADDRESS is going to be written with the data from the TSTWRITE register. This bit is self-cleared.	RW	0
20.13:11	Reserved			
20.10	TEST MODE	Enable the Testability/Configuration mode: 0 - Testability/Configuration mode disabled 1 - Testability/Configuration mode enabled	RW	0
20.9:5	READ ADDRESS	The address of the Testability/Configuration register that will be latched into the TSTREAD1 and TSTREAD2 registers	RW	0
20.4:0	WRITE ADDRESS	The address of the Testability/Configuration register that will be written.	RW	0

Table 5.45 Register 21 - TSTREAD1

ADDRESS	NAME	DESCRIPTION	MODE	DEFAULT
21.15:0	READ_DATA	When reading registers with a size of less than 16 bits, this register contains the register data, starting from bit 0. When reading registers with a size of more than 16 bits, this register contains the less significant 16 bits of the register data.	RO	0

Table 5.46 Register 22 - TSTREAD2

ADDRESS	NAME	DESCRIPTION	MODE	DEFAULT
22.15:0	READ_DATA	When reading registers with a size of less than 16 bits, this register clears to zeros. When reading registers with a size of more than 16 bits, this register contains the most significant bits of the register data, starting from the 16 th bit.	RO	0

Table 5.47 Register 23 - TSTWRITE

ADDRESS	NAME	DESCRIPTION	MODE	DEFAULT
23.15:0	WRITE_DATA	This field contains the data that will be written to a specific register on the "Programming" transaction.	RW	0

Table 5.48 Register 27 - Special Control/Status Indications

ADDRESS	NAME	DESCRIPTION	MODE	DEFAULT
27.15:13	Reserved		RW	0
27.12	SWRST_FAST	1 = Accelerates SW reset counter from 256 ms to 10 us for production testing.	RW	0
27.11	SQEOFF	Disable the SQE test (Heartbeat): 0 - SQE test is enabled. 1 - SQE test is disabled.	RW, NASR	0
27.10	VCOFF_LP	Forces the Receive PLL 10M to lock on the reference clock at all times: 0 - Receive PLL 10M can lock on reference or line as needed (normal operation) 1 - Receive PLL 10M is locked on the reference clock. In this mode 10M data packets cannot be received.	RW, NASR	0
27.9	Reserved	Write as 0. Ignore on read.	RW	0
27.8	Reserved	Write as 0. Ignore on read.	RW	0
27.7	Reserved	Write as 0. Ignore on read	RW	0
27.6	Reserved	Write as 0. Ignore on read.	RW	0
27.5	Reserved	Write as 0. Ignore on read.	RW	
27.4	XPOL	Polarity state of the 10Base-T: 0 - Normal polarity 1 - Reversed polarity	RO	0
27.3:0	AUTONEGS	Auto-negotiation "ARB" State-machine state	RO	1011

Table 5.49 Register 28 - Special Internal Testability Controls

ADDRESS	NAME	DESCRIPTION	MODE	DEFAULT
28.15:0	Reserved	Do not write to this register. Ignore on read.	RW	N/A

Table 5.50 Register 29 - Interrupt Source Flags

ADDRESS	NAME	DESCRIPTION	MODE	DEFAULT
29.15:8	Reserved	Ignore on read.	RO/ LH	0
29.7	INT7	1 = ENERGYON generated 0 = not source of interrupt	RO/ LH	0

Table 5.50 Register 29 - Interrupt Source Flags (continued)

ADDRESS	NAME	DESCRIPTION	MODE	DEFAULT
29.6	INT6	1 = Auto-Negotiation complete 0 = not source of interrupt	RO/ LH	0
29.5	INT5	1 = Remote Fault Detected 0 = not source of interrupt	RO/ LH	0
29.4	INT4	1 = Link Down (link status negated) 0 = not source of interrupt	RO/ LH	0
29.3	INT3	1 = Auto-Negotiation LP Acknowledge 0 = not source of interrupt	RO/ LH	0
29.2	INT2	1 = Parallel Detection Fault 0 = not source of interrupt	RO/ LH	0
29.1	INT1	1 = Auto-Negotiation Page Received 0 = not source of interrupt	RO/ LH	0
29.0	Reserved		RO/ LH	0

Table 5.51 Register 30 - Interrupt Mask

ADDRESS	NAME	DESCRIPTION	MODE	DEFAULT
30.15:8	Reserved	Write as 0; ignore on read.	RO	0
30.7:0	Mask Bits	1 = interrupt source is enabled 0 = interrupt source is masked	RW	0

Table 5.52 Register 31 - PHY Special Control/Status

ADDRESS	NAME	DESCRIPTION	MODE	DEFAULT
31.15	Reserved	Do not write to this register. Ignore on read.	RW	0
31.14	Reserved			
31.13	Special	Must be set to 0	RW	0
31.12	Autodone	Auto-negotiation done indication: 0 = Auto-negotiation is not done or disabled (or not active) 1 = Auto-negotiation is done	RO	0
31.11:10	Reserved		RW	0
31.9:7	GPO[2:0]	General Purpose Output connected to signals GPO[2:0]	RW	0
31.6	Enable 4B5B	0 = Bypass encoder/decoder. 1 = enable 4B5B encoding/decoding. MAC Interface must be configured in MII mode.	RW	1
31.5	Reserved	Write as 0, ignore on Read.	RW	0

Table 5.52 Register 31 - PHY Special Control/Status (continued)

ADDRESS	NAME	DESCRIPTION	MODE	DEFAULT
31.4:2	Speed Indication	HCDSPEED value: [001]=10Mbps Half-duplex [101]=10Mbps Full-duplex [010]=100Base-TX Half-duplex [110]=100Base-TX Full-duplex	RO	000
31.1	Reserved	Write as 0; ignore on Read	RW	0
31.0	Scramble Disable	0 = enable data scrambling 1 = disable data scrambling,	RW	0

5.3 Management Interrupt

The Management interface supports an interrupt capability that is not a part of the IEEE 802.3 specification. It generates an active low interrupt signal on the nINT output whenever certain events are detected. Reading the Interrupt Source register (Register 29) shows the source of the interrupt, and clears the interrupt output signal. The Interrupt Mask register (Register 30) enables for each source to set (LOW) the nINT, by asserting the corresponding mask bit. The Mask bit does not mask the source bit in register 29. At reset, all bits are masked (negated). The nINT is an asynchronous output.

INTERRUPT SOURCE	SOURCE/MASK REG BIT #
ENERGYON activated	7
Auto-Negotiate Complete	6
Remote Fault Detected	5
Link Status negated (not asserted)	4
Auto-Negotiation LP Acknowledge	3
Parallel Detection Fault	2
Auto-Negotiation Page Received	1

5.4 Miscellaneous Functions

5.4.1 Carrier Sense

The carrier sense is output on CRS. CRS is a signal defined by the MII specification in the IEEE 802.3u standard. The PHY asserts CRS based only on receive activity whenever the PHY is either in repeater mode or full-duplex mode. Otherwise the PHY asserts CRS based on either transmit or receive activity.

The carrier sense logic uses the encoded, unscrambled data to determine carrier activity status. It activates carrier sense with the detection of 2 non-contiguous zeros within any 10 bit span. Carrier sense terminates if a span of 10 consecutive ones is detected before a /J/K/ Start-of Stream Delimiter pair. If an SSD pair is detected, carrier sense is asserted until either /T/R/ End-of-Stream Delimiter pair or a pair of IDLE symbols is detected. Carrier is negated after the /T/ symbol or the first IDLE. If /T/ is not followed by /R/, then carrier is maintained. Carrier is treated similarly for IDLE followed by some non-IDLE symbol.

5.4.2 Collision Detect

A collision is the occurrence of simultaneous transmit and receive operations. The COL output is asserted to indicate that a collision has been detected. COL remains active for the duration of the collision. COL is changed asynchronously to both RX_CLK and TX_CLK. The COL output becomes inactive during full duplex mode.

COL may be tested by setting register 0, bit 7 high. This enables the collision test. COL will be asserted within 512 bit times of TX_EN rising and will be de-asserted within 4 bit times of TX_EN falling.

In 10M mode, COL pulses for approximately 10 bit times (1 μ s), 2 μ s after each transmitted packet (de-assertion of TX_EN). This is the Signal Quality Error (SQE) signal and indicates that the transmission was successful. The user can disable this pulse by setting bit 11 in register 27.

5.4.3 Isolate Mode

The PHY data paths may be electrically isolated from the MII by setting register 0, bit 10 to a logic one. In isolation mode, the PHY does not respond to the TXD, TX_EN and TX_ER inputs. The PHY still responds to management transactions.

Isolation provides a means for multiple PHYs to be connected to the same MII without contention occurring. The PHY is not isolated on power-up (bit 0:10 = 0).

5.4.4 Link integrity Test

The LAN83C185 performs the link integrity test as outlined in the IEEE 802.3u (Clause 24-15) Link Monitor state diagram. The link status is multiplexed with the 10Mbps link status to form the reportable link status bit in Serial Management Register 1, and is driven to the LINKON LED.

The DSP indicates a valid MLT-3 waveform present on the RXP and RXN signals as defined by the ANSI X3.263 TP-PMD standard, to the Link Monitor state-machine, using internal signal called DATA_VALID. When DATA_VALID is asserted the control logic moves into a Link-Ready state, and waits for an enable from the Auto Negotiation block. When received, the Link-Up state is entered, and the Transmit and Receive logic blocks become active. Should Auto Negotiation be disabled, the link integrity logic moves immediately to the Link-Up state, when the DATA_VALID is asserted.

Note that to allow the line to stabilize, the link integrity logic will wait a minimum of 330 μ sec from the time DATA_VALID is asserted until the Link-Ready state is entered. Should the DATA_VALID input be negated at any time, this logic will immediately negate the Link signal and enter the Link-Down state.

When the 10/100 digital block is in 10Base-T mode, the link status is from the 10Base-T receiver logic.

5.4.5 Power-Down modes

There are 2 power-down modes for the Phy:

5.4.5.1 General Power-Down

This power-down is controlled by register 0, bit 11. In this mode the entire PHY, except the management interface, is powered-down and stays in that condition as long as bit 0.11 is HIGH. When bit 0.11 is cleared, the PHY powers up and is automatically reset.

5.4.5.2 Energy Detect Power-Down

This power-down mode is activated by setting bit 17.13 to 1. In this mode when no energy is present on the line the PHY is powered down, except for the management interface, the SQUELCH circuit and the ENERGYON logic. The ENERGYON logic is used to detect the presence of valid energy from 100Base-TX, 10Base-T, or Auto-negotiation signals

In this mode, when the ENERGYON signal is low, the PHY is powered-down, and nothing is transmitted. When energy is received - link pulses or packets - the ENERGYON signal goes high, and

the PHY powers-up. It automatically resets itself into the state it had prior to power-down, and asserts the nINT interrupt if the ENERGYON interrupt is enabled. The first and possibly the second packet to activate ENERGYON may be lost.

When 17.13 is low, energy detect power-down is disabled.

5.4.6 Reset

The PHY has 3 reset sources:

Hardware reset (HWRST): connected to the nRST input, and to the internal POR signal.

If the nRST input is driven by an external source, it should be held LOW for at least 100 us to ensure that the Phy is properly reset.

The Phy has an internal Power-On-Reset (POR) signal which is asserted for 21ms following a VDD (+3.3V) and VDDCORE (+1.8V) power-up. This internal POR can be bypassed only in certain production test modes. This internal POR is internally “OR”-ed with the nRST input.

During a Hardware reset, either external or POR, an external clock *must* be supplied to the CLKIN signal.

Software (SW) reset: Activated by writing register 0, bit 15 high. This signal is self-clearing. After the register-write, internal logic extends the reset by 256µs to allow PLL-stabilization before releasing the logic from reset.

The IEEE 802.3u standard, clause 22 (22.2.4.1.1) states that the reset process should be completed within 0.5s from the setting of this bit.

Power-Down reset: Automatically activated when the PHY comes out of power-down mode. The internal power-down reset is extended by 256µs after exiting the power-down mode to allow the PLLs to stabilize before the logic is released from reset.

These 3 reset sources are combined together in the digital block to create the internal “general reset”, SYSRST, which is an asynchronous reset and is active HIGH. This SYSRST directly drives the PCS, DSP and MII blocks. It is also input to the Central Bias block in order to generate a short reset for the PLLs.

The SMI mechanism and registers are reset only by the Hardware and Software resets. During Power-Down, the SMI registers are not reset. Note that some SMI register bits are not cleared by Software reset – these are marked “NASR” in the register tables.

For the first 16us after coming out of reset, the MII will run at 2.5 MHz. After that it will switch to 25 MHz if auto-negotiation is enabled.

5.4.7 LED Description

The PHY provides four LED signals. These provide a convenient means to determine the mode of operation of the Phy. All LED signals are either active high or active low.

Note: The four LED signals can be either active-high or active-low. Polarity depends upon the Phy address latched in on reset. The LAN83C185 senses each Phy address bit and changes the polarity of the LED signal accordingly. If the address bit is set as level “1”, the LED polarity will be set to an active-low. If the address bit is set as level “0”, the LED polarity will be set to an active-high.

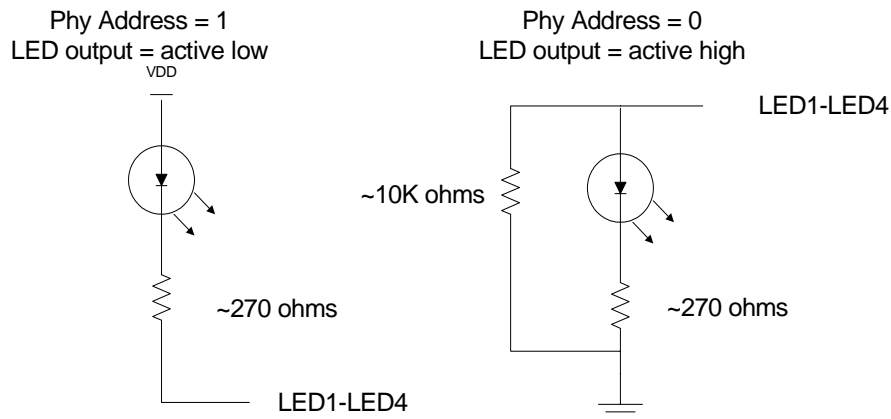

Figure 5.1 PHY Address Strapping on LEDs

The ACTIVITY LED output is driven active when CRS is active (high). When CRS becomes inactive, the Activity LED output is extended by 128ms.

The LINKON LED output is driven active whenever the PHY detects a valid link. The use of the 10Mbps or 100Mbps link test status is determined by the condition of the internally determined speed selection.

The SPEED100 LED output is driven active when the operating speed is 100Mbit/s or during Auto-negotiation. This LED will go inactive when the operating speed is 10Mbit/s or during line isolation (register 31 bit 5).

The Full-Duplex LED output is driven active low when the link is operating in Full-Duplex mode.

5.4.8 Loopback Operation

The 10/100 digital has two independent loop-back modes: Internal loopback and far loopback.

5.4.8.1 Internal Loopback

The internal loopback mode is enabled by setting bit register 0 bit 14 to logic one. In this mode, the scrambled transmit data (output of the scrambler) is looped into the receive logic (input of the descrambler). The COL signal will be inactive in this mode, unless collision test (bit 0.7) is active.

In this mode, during transmission (TX_EN is HIGH), nothing is transmitted to the line and the transmitters are powered down.

5.4.9 Configuration Signals

The PHY has 11 configuration signals whose inputs should be driven continuously, either by external logic or external pull-up/pull-down resistors.

5.4.9.1 Physical Address Bus - PHYAD[4:0]

The PHYAD[4:0] signals are driven high or low to give each PHY a unique address. This address is latched into an internal register at end of hardware reset. In a multi-PHY application (such as a repeater), the controller is able to manage each PHY via the unique address. Each PHY checks each management data frame for a matching address in the relevant bits. When a match is recognized, the PHY responds to that particular frame. The PHY address is also used to seed the scrambler. In a multi-PHY application, this ensures that the scramblers are out of synchronization and disperses the electromagnetic radiation across the frequency spectrum.

5.4.9.2 Mode Bus – MODE[2:0]

The MODE[2:0] bus controls the configuration of the 10/100 digital block.

Table 5.53 MODE[2:0] Bus

MODE[2:0]	MODE DEFINITIONS	DEFAULT REGISTER BIT VALUES	
		REGISTER 0	REGISTER 4
		[13,12,10,8]	[8,7,6,5]
000	10Base-T Half Duplex. Auto-negotiation disabled.	0000	N/A
001	10Base-T Full Duplex. Auto-negotiation disabled.	0001	N/A
010	100Base-TX Half Duplex. Auto-negotiation disabled. CRS is active during Transmit & Receive.	1000	N/A
011	100Base-TX Full Duplex. Auto-negotiation disabled. CRS is active during Receive.	1001	N/A
100	100Base-TX Half Duplex is advertised. Auto-negotiation enabled. CRS is active during Transmit & Receive.	1100	0100
101	Repeater mode. Auto-negotiation enabled. 100Base-TX Half Duplex is advertised. CRS is active during Receive.	1100	0100
110	Power Down mode. In this mode the PHY wake-up in Power-Down mode.	N/A	N/A
111	All capable. Auto-negotiation enabled.	X10X	1111

5.5 Analog

The analog blocks of the chip are described in this section.

5.5.1 ADC

The ADC is a 6 bit 125 MHz sample rate Analog to Digital Converter designed to serve as the analog front end of a digital 100Base-Tx receiver.

5.5.1.1 Functional Description

The ADC has a full flash architecture for maximum speed and minimum latency. An internally generated 125MHz clock is used to time the sampling and processing.

The ADC has a variable gain, which is controlled by the DSP block. This allows accurate A/D conversion over the entire range of input signal amplitudes, which is particularly important for lower amplitude signals (longer cables).

5.5.1.1.1 INPUT COMMON MODE

The differential input is applied to the RXP/N signals. For proper operation of the ADC the input common mode should match the internal differential reference common mode. To achieve this, the ADC generates the appropriate voltage and drives it via the VCOM signal.

Datasheet

5.5.1.2 General Characteristics

ITEM	SPEC	UNITS	REMARK
Full Scale Input voltage	3.0 Differential (peak-to-peak)	V	
Input Common Mode	1.6-2.0	V	Gain dependent.

5.5.2 100M PLL

Three main functions are included in the 100M PLL: a clock multiplier to generate a 125MHz clock, a phase interpolator to synchronize the receive clock to the receive data, and a transmit wave-shaping delay reference.

5.5.2.1 Functional Description

The clock multiplier generates a multiple phase 125MHz from a 25MHz reference frequency.

The phase interpolator uses a multiplexer to select the phase used as the receive clock, RX_CLK. The multiplexer is controlled by signals generated in the DSP Timing unit. The Timing unit estimates the frequency drift of the received data clock and, by incrementing, decrementing or maintaining the selected phase, it generates a clock that is synchronized to the received data stream.

The 100M PLL also generates a fixed phase 125MHz clock, slaved to the VCO, that is used by the digital filter for accurate wave-shaping of the transmit output. It is also used as the transmitter clock of the PHY, TX_CLK. (This clock must be jitter-free thus cannot be the receive clock).

5.5.3 MT_100

This block generates the differential outputs driven onto TXP/TXN in 100Base-TX mode.

5.5.3.1 Functional Description

This block is a wave-shaped 100BASE-TX transmitter, with high impedance current outputs. The three level differential output (MLT-3) is shaped by differential current switches whose outputs are connected together. The low pass filtering (wave-shaping) of the current output is done by progressive switching of small current sources. The timing reference for the wave-shaping is the 125MHz fixed clock from the 100M PLL. The transmitter is designed to operate with a 1:1 transformer.

5.5.4 10M Squelch

The squelch circuit consists of squelch comparators and data comparators, which operate according to the 802.3 standard in Section 14.3.1.3.2.

5.5.5 10BT Filter

The 10BASE-T Low Pass Filter is the front end of 10BASE-T signal path. It is designed to reject the high frequency noise from entering the squelch and data recovery blocks.

5.5.6 10M PLL - Data Recovery Clock

The data recovery Phase Locked Loop (PLL) is used for data recovery for the 10BASE-T mode of operation. The data recovery PLL is used to synchronize the phase of the 10BASE-T data and the 20MHz VCO.

5.5.6.1 Functional Description

The Data recovery PLL has two modes of operation: Frequency Mode and Data Mode.

In frequency mode, the VCO locks to the external reference clock.

In Data mode, the VCO locks to the incoming data. When the PLL switches to Data mode, the VCO is held. It is released on an incoming data edge. This provides a minimum amount of phase error when the PLL switches from Frequency Mode to Data Mode.

5.5.7 PLL 10M - Transmit Clock

The transmit Phase Locked Loop (PLL) is used to generate a precise delay for the 10BASE-T transmitter. It also provides a 20MHz clock for the transmit digital block.

5.5.7.1 Functional Description

This PLL is used to provide a Transmit clock to the digital and create a delay for the 10BASE-T transmitter.

The Transmit PLL operates continuously in a frequency mode of operation where it is locked to the input clock.

5.5.8 XMT_10

This block generates the differential outputs driven onto TXP/TXN in 10Base-T mode.

5.5.8.1 Functional Description

This block is a wave-shaped 10BASE-T transmitter, with high impedance current outputs. The low pass filtering (wave-shaping) of the current output is done by progressive switching of small current sources. The timing reference for the wave-shaping is the 10BASE-T transmit PLL. The transmitter is designed to operate with a 1:1 turn-ratio transformer.

5.5.9 Central Bias

The Central Bias block generates a power-up reset signal, a PLL reset signal and the bias currents/voltages needed by other on-chip blocks.

5.5.9.1 Functional Description

This block has three main functions: Reference bias current and voltage generator, power-up reset, and PLL reset.

The bias generator generates accurate currents and voltages using an on-chip bandgap circuit and an external 12.4K 1% resistor.

The power-up reset circuit generates a signal that stays high for 10 ms. This duration is controlled through the use of counters and a 25MHz internal clock. An analog power-up circuit is used to set the initial conditions and ensure proper startup of the circuit.

The PLL reset signal is generated after the occurrence of an active nRST. The internal reset signal is asserted for the duration of four 25MHz clocks (160ns). It is then released. Releasing the PLL reset early ensures that the PLL locks to the reference clock before the system reset (nRST) is released.

5.6 DSP Block

5.6.1 General Description

The “DSP Block” includes the following modules:

DSP Core (Equalizer, Timing and BLW correction), Testability / Configuration module (Testability / Configuration control), Testability / Configuration Registers (not including any SMI registers) and the Multiplexers (for the testability / configuration signals).

The details of the DSP core are described in the DSP architecture specification. The Testability / Configuration features give access to the status and control of most of the internal registers in the DSP. The status and control mechanisms are described in the architecture specification.

5.6.2 ADC Gray code converting

The LAN83C185 ADC generates a 6 bit “modified” Gray code. Normal Gray code outputs number in the range of 0 to $2^n - 1$. The 6-bit code generates numbers from 0 to 63 (decimal).

The MLT3 analog input has a voltage range of $-1V$ to $+1V$. It is necessary to translate this to -32 to $+31$ on the output of the ADC. Thus the Gray Code is modified by offsetting it by -32 . This is translated to 2’s complement before being presented to the DSP.

Chapter 6 Electrical Characteristics

The timing diagrams and limits in this section define the requirements placed on the external signals of the Phy.

6.1 Serial Management Interface (SMI) Timing

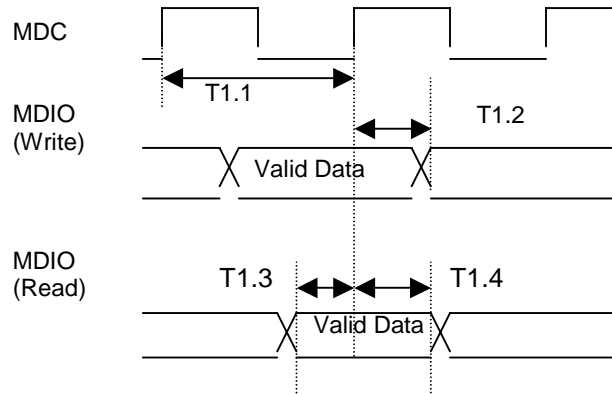

PARAMETER	DESCRIPTION	MIN	TYP	MAX	UNITS	NOTES
T1.1	MDC frequency			2.5	MHz	
T1.2	MDC to MDIO (Write) delay	0		300	ns	
T1.3	MDIO (Read) to MDC setup	10			ns	
T1.4	MDIO (Read) to MDC hold	10			ns	

Datasheet

6.2 100Base-TX Timings

6.2.1 100M MII Receive Timing

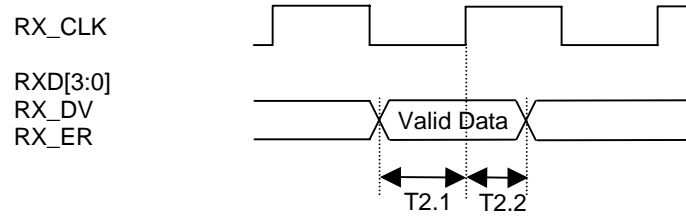

PARAMETER	DESCRIPTION	MIN	TYP	MAX	UNITS	NOTES
T2.1	Receive signals setup to RX_CLK rising	10			ns	
T2.2	Receive signals hold from RX_CLK rising	10			ns	
	RX_CLK frequency		25		MHz	
	RX_CLK Duty-Cycle		40		%	

6.2.2 100M MII Transmit Timing

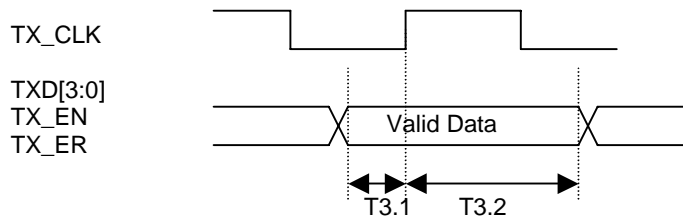

PARAMETER	DESCRIPTION	MIN	TYP	MAX	UNITS	NOTES
T3.1	Transmit signals setup to TX_CLK rising	12			ns	
T3.2	Transmit signals hold after TX_CLK rising	0			ns	
	TX_CLK frequency		25		MHz	
	TX_CLK Duty-Cycle		40		%	

6.3 10Base-T Timings

6.3.1 10M MII Receive Timing

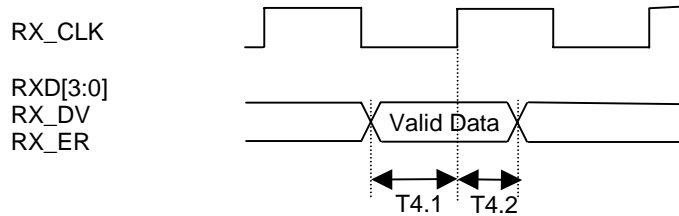

PARAMETER	DESCRIPTION	MIN	TYP	MAX	UNITS	NOTES
T4.1	Receive signals setup to RX_CLK rising	10			ns	
T4.2	Receive signals hold from RX_CLK rising	10			ns	
	RX_CLK frequency		25		MHz	
	RX_CLK Duty-Cycle		40		%	
	Receive signals setup to RX_CLK rising	10			ns	

6.3.2 10M MII Transmit Timing

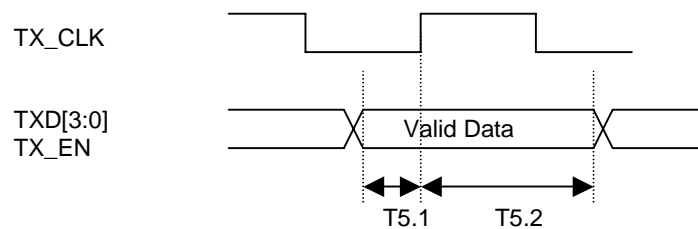

PARAMETER	DESCRIPTION	MIN	TYP	MAX	UNITS	NOTES
T5.1	Transmit signals setup to TX_CLK rising	12			ns	
T5.2	Transmit signals hold after TX_CLK rising			0	ns	
	TX_CLK frequency		2.5		MHz	
	TX_CLK Duty-Cycle		50		%	

6.4 Reset Timing

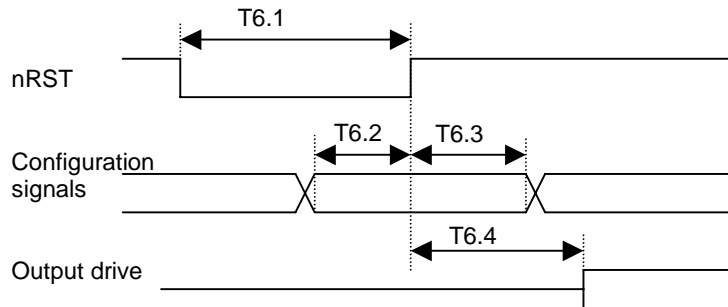

PARAMETER	DESCRIPTION	MIN	TYP	MAX	UNITS	NOTES
T6.1	Reset Pulse Width	100			us	
T6.2	Configuration input setup to nRST rising	200			ns	
T6.3	Configuration input hold after nRST rising	400			ns	
T6.4	Output Drive after nRST rising	20		800	ns	20 clock cycles for 25 MHz clock

6.5 DC Characteristics

6.5.1 Operating Conditions

Supply Voltage +3.3V +/- 10%

Operating Temperature 0°C to 70°C

6.5.2 Power Consumption

6.5.2.1 Power Consumption Device Only

Power measurements taken under the following conditions:

Temperature: +25° C

Device VDD: +3.30 V

Table 6.1 Power Consumption Device Only

Mode	Total Power (mW)	DIGITAL POWER		ANALOG POWER		REGULATOR SUPPLY CURRENT	
		Power (mW)	Current (mA)	Power (mW)	Current (mA)	Power (mW)	Current (mA)
10BASE-T Operation							
10BASE-T /w traffic	96	33	10	59	18	4	1
Idle	83	20	6	59	18	4	1
Energy Detect Power Down	45	17	5	24	7	4	1
AN General Power Down	45	17	5	24	7	4	1
Non-AN Gen Power Down	22	17	5	0.66	0.200	4	1
100BASE-TX Operation							
100BASE-TX /w traffic	261	66	20	132	40	63	19
Idle	245	50	15	132	40	63	19
Energy Detect Power Down	45	17	5	24	7	4	1
AN General Power Down	45	17	5	24	7	4	1
Non-AN Gen Power Down	22	17	5	0.66	0.200	4	1

Notes:

1. Each LED indicator in use adds approximately 4 mA to the Digital power supply.
2. Digital Power pins on LAN83C185 are: VDD pins 8, 18, 43.
3. Analog Power pins on LAN83C185 are: AVDD pins 53, 57, 61, 63.
4. Regulator Supply pins on LAN83C185 are: VREG pin 13.
5. Traffic Utilization = 100%
6. Mode of Operation in both cases is full duplex.

Datasheet

6.5.2.2 Power Consumption Device and System Components

Power measurements taken under the following conditions:

Temperature: +25° C

Device VDD: +3.30 V

Table 6.2 Power Consumption Device and System Components

Mode	Total Power (mW)	DIGITAL POWER		ANALOG POWER		REGULATOR SUPPLY CURRENT	
		Power (mW)	Current (mA)	Power (mW)	Current (mA)	Power (mW)	Current (mA)
10BASE-T Operation							
10BASE-T /w traffic	476	33	10	439	133	4	1
Idle	463	20	6	439	133	4	1
Energy Detect Power Down	45	17	5	24	7	4	1
AN General Power Down	45	17	5	24	7	4	1
Non-AN Gen Power Down	22	17	5	.66	.200	4	1
100BASE-TX Operation							
100BASE-TX /w traffic	400	66	20	271	82	63	19
Idle	384	50	15	271	82	63	19
Energy Detect Power Down	45	17	5	24	7	4	1
AN General Power Down	45	17	5	24	7	4	1
Non-AN Gen Power Down	22	17	5	.66	.200	4	1

Notes:

1. Each LED indicator in use adds approximately 4 mA to the Digital power supply.
2. Digital Power pins on LAN83C185 are: VDD pins 8, 18, 43.
3. Analog Power pins on LAN83C185 are: AVDD pins 53, 57, 61, 63.
4. Regulator Supply pins on LAN83C185 are: VREG pin 13.
5. Traffic Utilization = 100%
6. Mode of Operation in both cases is full duplex.

6.5.3 DC Characteristics - Input and Output Buffers

Table 6.3 MII Bus Interface Signals

PIN NO.	NAME	V _{IH}	V _{IL}	I _{OH}	I _{OL}	V _{OL}	V _{OH}
41	TXD0	+2.0 V	+0.8 V				
42	TXD1	+2.0 V	+0.8 V				
44	TXD2	+2.0 V	+0.8 V				
45	TXD3	+2.0 V	+0.8 V				
37	TX_ER/TXD4	+2.0 V	+0.8 V				
39	TX_EN	+2.0 V	+0.8 V				
38	TX_CLK			-8 mA	+8 mA	+0.4 V	VDD – +0.4 V
32	RXD0			-8 mA	+8 mA	+0.4 V	VDD – +0.4 V
31	RXD1			-8 mA	+8 mA	+0.4 V	VDD – +0.4 V
30	RXD2			-8 mA	+8 mA	+0.4 V	VDD – +0.4 V
29	RXD3			-8 mA	+8 mA	+0.4 V	VDD – +0.4 V
35	RX_ER/RXD4			-8 mA	+8 mA	+0.4 V	VDD – +0.4 V
33	RX_DV			-8 mA	+8 mA	+0.4 V	VDD – +0.4 V
34	RX_CLK			-8 mA	+8 mA	+0.4 V	VDD – +0.4 V
48	CRS			-8 mA	+8 mA	+0.4 V	VDD – +0.4 V
47	COL			-8 mA	+8 mA	+0.4 V	VDD – +0.4 V
27	MDC	+2.0 V	+0.8 V				
26	MDIO			-8 mA	+8 mA	+0.4 V	VDD – +0.4 V

Table 6.4 LAN Interface Signals

PIN NO.	NAME		V_{IH}	V_{IL}	I_{OH}	I_{OL}	V_{OL}	V_{OH}
51	TXP	See Table 6.10, "100Base-TX Transceiver Characteristics," on page 59 and Table 6.11, "10BASE-T Transceiver Characteristics," on page 59.						
50	TXN							
55	RXP							
54	RXN							

Table 6.5 LED Signals

PIN NO.	NAME	V_{IH}	V_{IL}	I_{OH}	I_{OL}	V_{OL}	V_{OH}
16	SPEED100	+2.0 V	+0.8 V	-12 mA	+24 mA	+0.4 V	VDD – +0.4 V
17	LINKON	+2.0 V	+0.8 V	-12 mA	+24 mA	+0.4 V	VDD – +0.4 V
19	ACTIVITY	+2.0 V	+0.8 V	-12 mA	+24 mA	+0.4 V	VDD – +0.4 V
20	FDUPLEX	+2.0 V	+0.8 V	-12 mA	+24 mA	+0.4 V	VDD – +0.4 V

Table 6.6 Configuration Inputs

PIN NO.	NAME	V_{IH}	V_{IL}	I_{OH}	I_{OL}	V_{OL}	V_{OH}
16	PHYAD0	+2.0 V	+0.8 V	-12 mA	+24 mA	+0.4 V	VDD – +0.4 V
17	PHYAD1	+2.0 V	+0.8 V	-12 mA	+24 mA	+0.4 V	VDD – +0.4 V
19	PHYAD2	+2.0 V	+0.8 V	-12 mA	+24 mA	+0.4 V	VDD – +0.4 V
20	PHYAD3	+2.0 V	+0.8 V	-12 mA	+24 mA	+0.4 V	VDD – +0.4 V
2	PHYAD4			-4 mA	+8 mA	+0.4 V	VDD – +0.4 V
4	MODE0	+2.0 V	+0.8 V				
5	MODE1	+2.0 V	+0.8 V				
6	MODE2	+2.0 V	+0.8 V				
9	TEST0	+2.0 V	+0.8 V				
10	TEST1	+2.0 V	+0.8 V				
11	CLK_FREQ	+2.0 V	+0.8 V				

Table 6.6 Configuration Inputs (continued)

PIN NO.	NAME	V _{IH}	V _{IL}	I _{OH}	I _{OL}	V _{OL}	V _{OH}
12	REG_EN						
1	MII			-4 mA	+8 mA	+0.4 V	VDD – +0.4 V

Table 6.7 General Signals

PIN NO.	NAME	V _{IH}	V _{IL}	I _{OH}	I _{OL}	V _{OL}	V _{OH}
1	GPO0			-4 mA	+8 mA	+0.4 V	VDD – +0.4 V
2	GPO1			-4 mA	+8 mA	+0.4 V	VDD – +0.4 V
3	GPO2			-4 mA	+8 mA	+0.4 V	VDD – +0.4 V
46	nINT			-4 mA	+8 mA	+0.4 V	VDD – +0.4 V
25	nRST						
23	CLKIN/XTAL1						
22	XTAL2						
64	NC1						

Table 6.8 Analog References

PIN NO.	NAME	V _{IH}	V _{IL}	I _{OH}	I _{OL}	V _{OL}	V _{OH}
59	EXRES1						
56	NC2						

Table 6.9 Internal Pull-Up / Pull-Down Configurations

PIN NO.	NAME	PULL-UP OR PULL-DOWN	TYPE
1	GPO0/MII	Pull-down	30 uA
2	GPO1/PHYAD4	Pull-up	30 uA
4	MODE0	Pull-up	30 uA
5	MODE1	Pull-up	30 uA
6	MODE2	Pull-up	30 uA
9	TEST0	Pull-down	30 uA
10	TEST1	Pull-down	30 uA

Table 6.9 Internal Pull-Up / Pull-Down Configurations (continued)

PIN NO.	NAME	PULL-UP OR PULL-DOWN	TYPE
16	SPEED100	Pull-up	30 uA
17	LINKON	Pull-up	30 uA
19	ACTIVITY	Pull-up	30 uA
20	FDUPLEX	Pull-up	30 uA
46	nINT	Pull-up	30 uA

Table 6.10 100Base-TX Transceiver Characteristics

PARAMETER	SYMBOL	MIN	TYP	MAX	UNITS	NOTES
Peak Differential Output Voltage High	V_{PPH}	950	-	1050	mVpk	Note 6.1
Peak Differential Output Voltage Low	V_{PPL}	-950	-	-1050	mVpk	Note 6.1
Signal Amplitude Symmetry	V_{SS}	98	-	102	%	Note 6.1
Signal Rise & Fall Time	T_{RF}	3.0	-	5.0	nS	Note 6.1
Rise & Fall Time Symmetry	T_{RFS}	-	-	0.5	nS	Note 6.1
Duty Cycle Distortion	D_{CD}	35	50	65	%	Note 6.2
Overshoot & Undershoot	V_{OS}	-	-	5	%	
Jitter				1.4	nS	Note 6.3

Note 6.1 Measured at the line side of the transformer, line replaced by 100Ω (+/- 1%) resistor.

Note 6.2 Offset from 16 nS pulse width at 50% of pulse peak

Note 6.3 Measured differentially.

Table 6.11 10BASE-T Transceiver Characteristics

PARAMETER	SYMBOL	MIN	TYP	MAX	UNITS	NOTES
Transmitter Peak Differential Output Voltage	V_{OUT}	2.2	2.5	2.8	V	Note 6.4
Receiver Differential Squelch Threshold	V_{DS}	300	420	585	mV	

Note 6.4 Min/max voltages guaranteed as measured with 100Ω resistive load.

Chapter 7 Package Outline

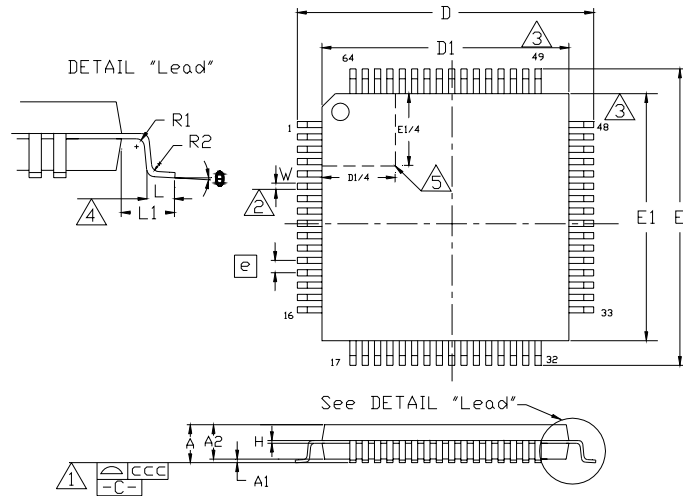

Figure 7.1 64 Pin TQFP Package Outline, 10X10X1.4 Body, 2 MM Footprint

Table 7.1 64 Pin TQFP Package Parameters

	MIN	NOMINAL	MAX	REMARKS
A	~	~	1.60	Overall Package Height
A1	0.05	~	0.15	Standoff
A2	1.35	~	1.45	Body Thickness
D	11.80	~	12.20	X Span
D1	9.80	~	10.20	X body Size
E	11.80	~	12.20	Y Span
E1	9.80	~	10.20	Y body Size
H	0.09	~	0.20	Lead Frame Thickness
L	0.45	0.60	0.75	Lead Foot Length
L1	~	1.00	~	Lead Length
e	0.50 Basic			Lead Pitch
θ	0°	~	7°	Lead Foot Angle
W	0.17	0.22	0.27	Lead Width
R	0.08	~	~	Lead Shoulder Radius
R2	0.08	~	0.20	Lead Foot Radius
ccc	~	~	0.08	Coplanarity

Notes:

- Controlling Unit: millimeter.
- Tolerance on the true position of the leads is ± 0.04 mm maximum.
- Package body dimensions D1 and E1 do not include the mold protrusion. Maximum mold protrusion is 0.25 mm per side.
- Dimension for foot length L measured at the gauge plane 0.25 mm above the seating plane.
- Details of pin 1 identifier are optional but must be located within the zone indicated.